











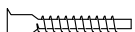





Before you begin, please follow assembly instruction carefully, then follow step by step.

Read instruction carefully. See furniture Parts List and Hardware List for guidance. Be sure you have all parts before you start assembling. Place and assemble furniture on a clean flat soft surface, such as carpet, rug or carton to prevent being scratched.

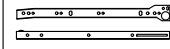
**Reminder :**

Please ensure that all surface and edges with colours / laminations are facing forward / outward.

| HARDWARE ITEM |   |                             | QTY     |
|---------------|---|-----------------------------|---------|
| A2            |    | Screw m3.5 x 14mm           | 82      |
| A7            |    | Screw m4 x 30mm             | 14      |
| A10           |    | Screw m4 x 38mm             | 4       |
| A17           |    | Crosshead Screw m6.3 x 40mm | 14      |
| A34           |    | Euro Screw m5 x 8mm         | 4       |
| D4            |    | Wood Dowel 6 x 25mm         | 4       |
| D6            |   | Wood Dowel 8 x 25mm         | 6       |
| E7            |  | Hinges 2/8                  | 8       |
| F2            |  | Mini Fix 15mm               | 18 Sets |

|     |   |                                      |          |
|-----|---|--------------------------------------|----------|
| H6  |    | Handle 128mm (Silver)                | 5        |
| L10 |    | PVC Round Leg 25mm                   | 4        |
| M6  |    | Drawer Metal Slide 350mm             | 1 Set    |
| N1  |    | Allen Key                            | 1        |
| N3  |    | Nail                                 | 20 (+-3) |
| Q4  |    | Plastic Shelf Support with Steel Pin | 12       |
| R2  |    | Single Plastic Cap                   | 28       |
| S2  |  | Door Stopper                         | 2        |
| Y   |  | Crosshead Cover                      | 4        |

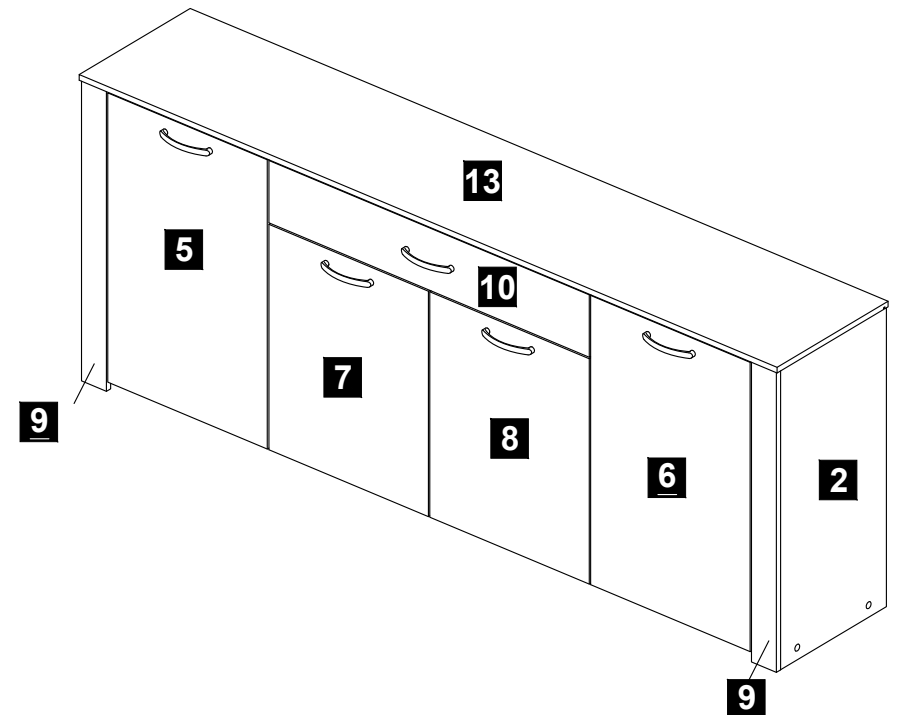

**CAUTION**

MATERIAL USE LAMINATED PARTICLE BOARD, TO CLEAN USE SOFT, DRY CLOTH. DO NOT USE DETERGENT OR CHEMICAL AVOID CONTACT WITH WATER AND DIRECT SUNLIGHT. TO BE ASSEMBLED ON A SOFT, DRY, CLEAN SMOOTH SURFACE.



USE OF POWER TOOLS TO ASSEMBLE THIS PRODUCT WILL INVALIDATE ANY CLAIM AND MAY DAMAGE THIS PRODUCT MAKING IT UNSAFE.

**PRE - ASSEMBLY**

**STEP 1** Insert the Plastic Shelf Support with Steel Pin (Q4) & Mini Fix Cam (F2) & Wood Dowel (D6) at panel no. 1 & 2.

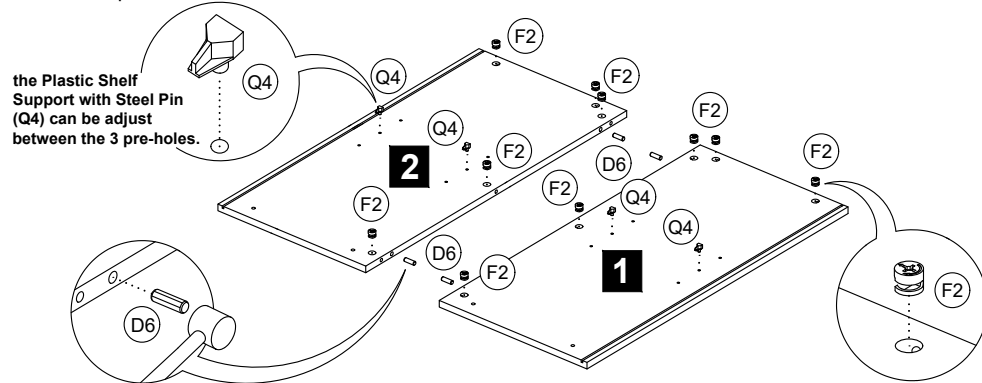

**STEP 2** Insert the Plastic Shelf Support with Steel Pin (Q4) & Mini Fix Cam (F2) at panel no. 3. Assemble the Drawer Metal Slide 350mm (M6) at marking hole panel no. 3.

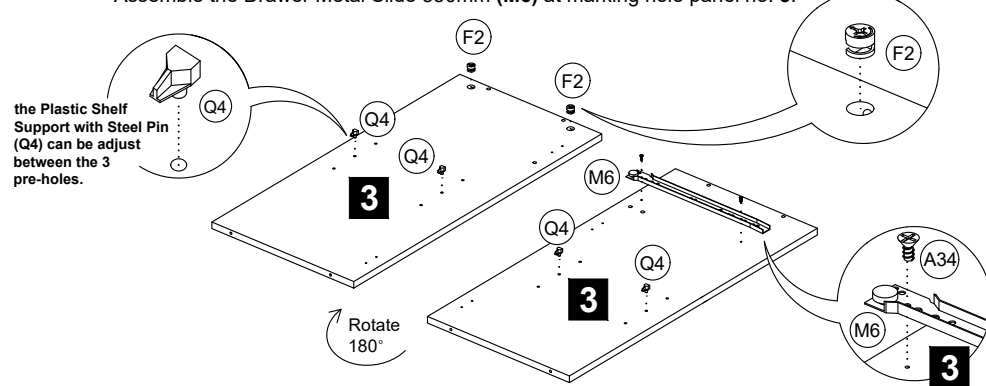

**STEP 3** Insert the Plastic Shelf Support with Steel Pin (Q4) & Mini Fix Cam (F2) at panel no. 4. Assemble the Drawer Metal Slide 350mm (M6) at marking hole panel no. 4.

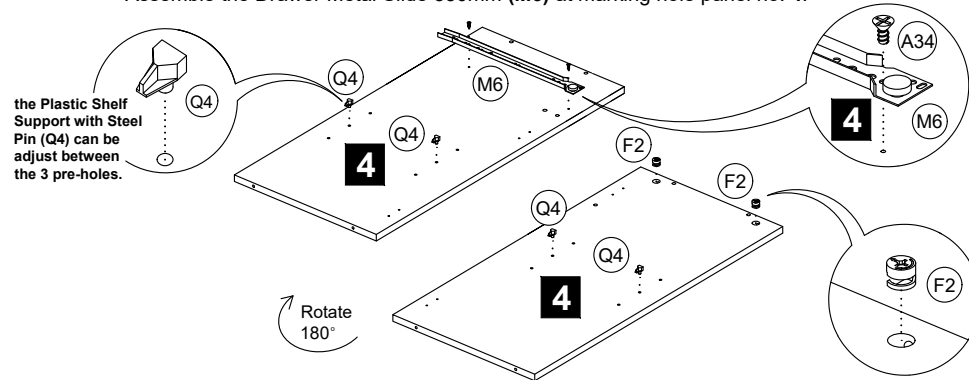

**PRE - ASSEMBLY**

**STEP 4** Insert the Mini Fix Bolt (F2) at panel no. 9 & 13. Insert the Door Stopper at panel no. 13. Insert the Wood Dowel (D6) at panel no. 17.

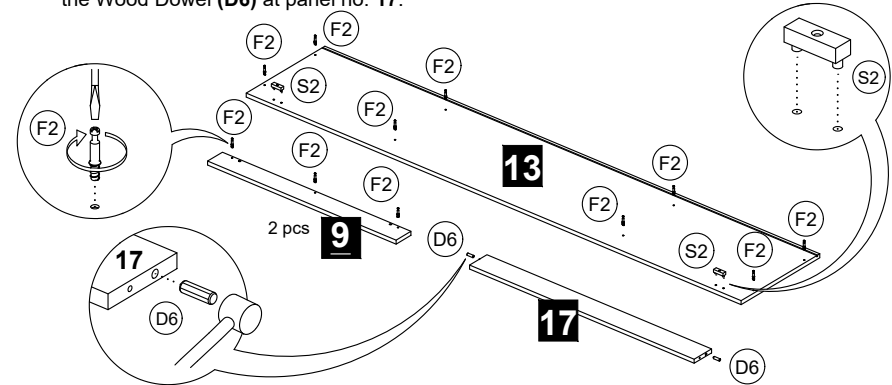

**STEP 5** Assemble the Hinges 2/8 (E7) at panel no. 5 & 6 by using Screw m3.5 x 14mm (A2).

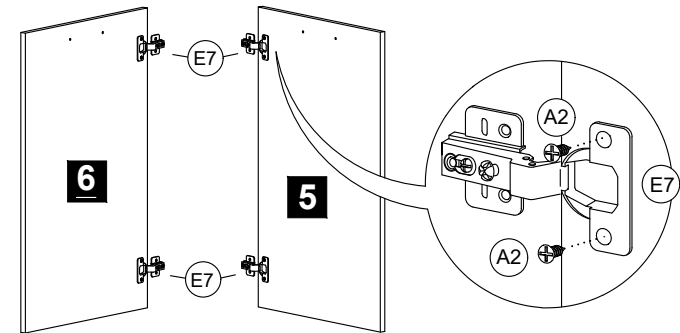

**STEP 6** Assemble the Hinges 2/8 (E7) at panel no. 7 & 8 by using Screw m3.5 x 14mm (A2).

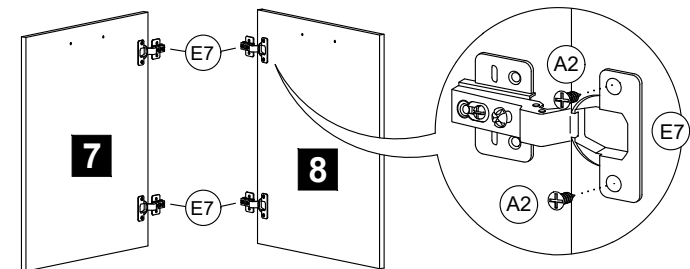

**STEP 7** Fix the Mini Fix Bolt (F2) & Use Screw m4 x 30mm (A7) to assemble the Handle (H6) at panel no. 10. Then insert the Mini Fix Cam (F2) at panel no. 11 & 12. Insert the Wood Dowel 6 x 25mm (D4) at panel no. 19.

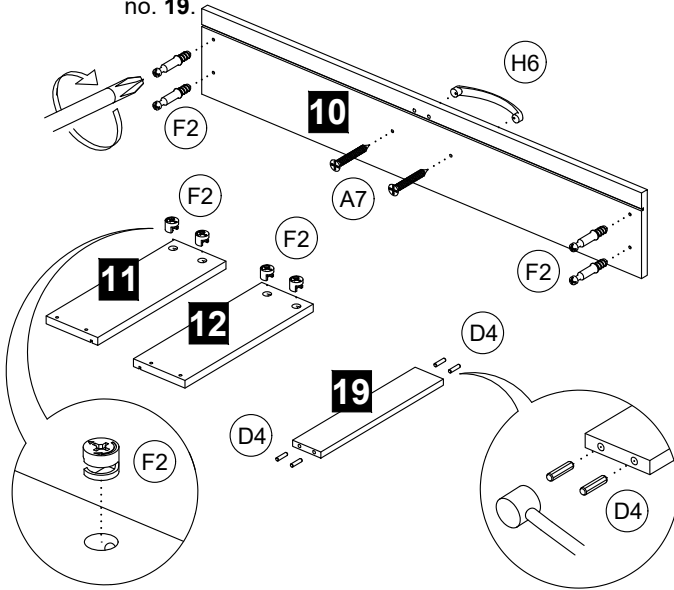

**STEP 8** Assemble the panel no. 11, 12 & 18 together with Screw m4 x 38mm (A10).

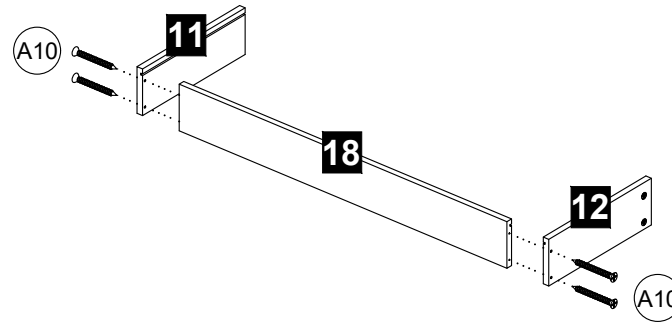

**STEP 9** Slide the panel no. 22 along the groove until end & attach the panel no. 19 by using Wood Dowel 6 x 25mm (D4).

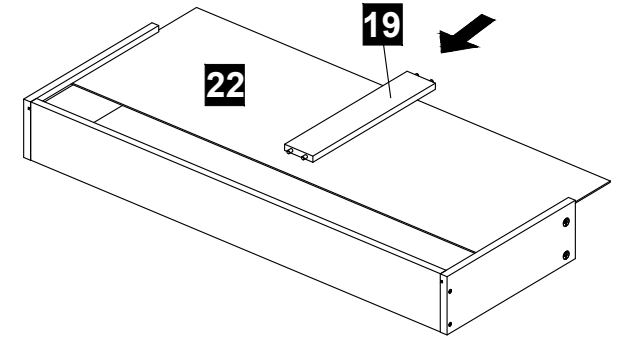

**STEP 10** Assemble the panel no. 10 by using Mini Fix 15mm (F2).

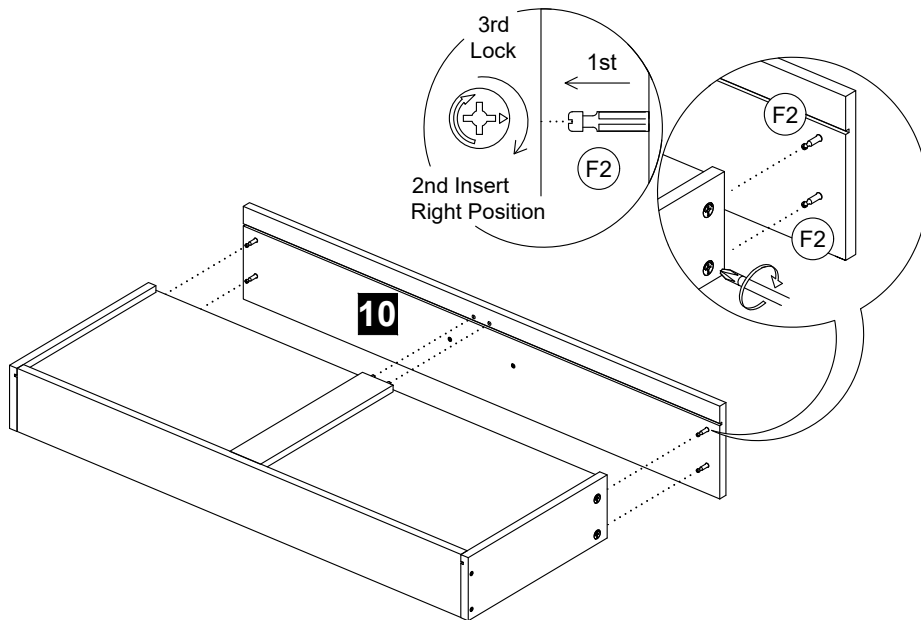

**STEP 11** Using Screw m3.5 x 14mm (A2) to assemble the Drawer Metal Slide 350mm (M6) & Single Plastic Cap (R2) to secure the Drawer.

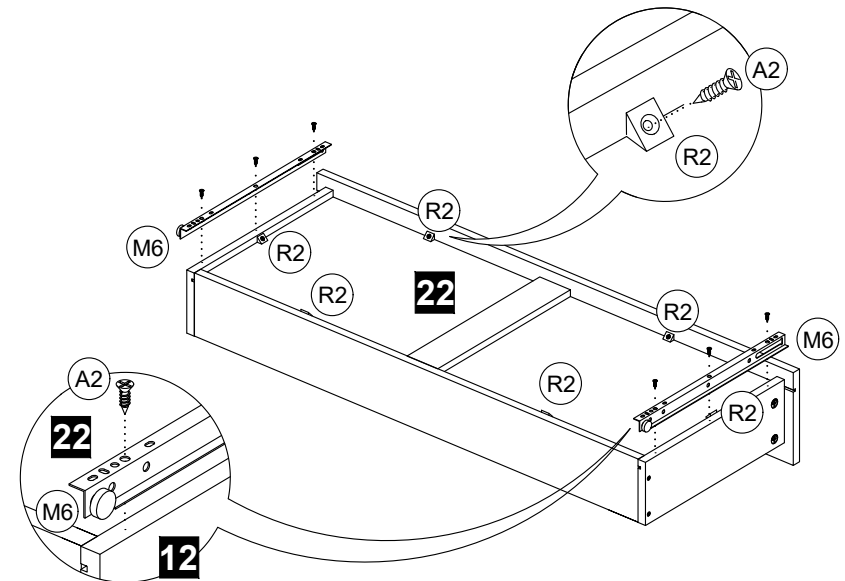

**STEP 12** Assemble the panel no. **1** & **9**, **2** & **9** together by using Mini Fix 15mm (**F2**).

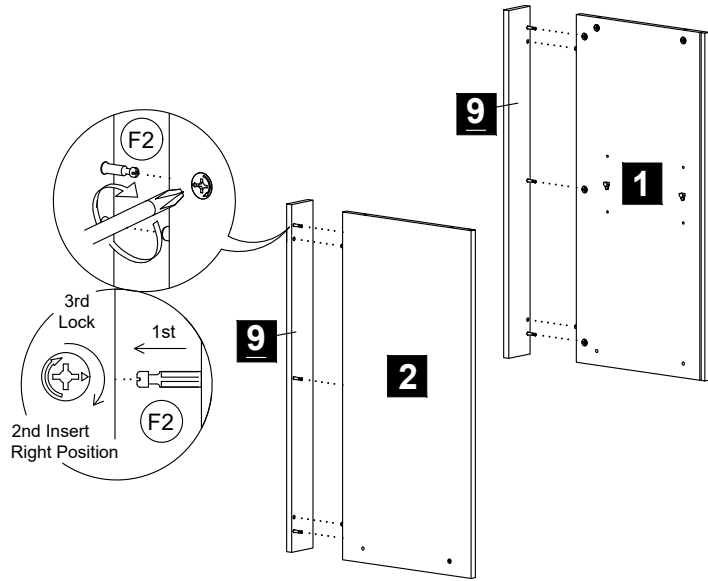

**STEP 13** Assemble the panel no. **3**, **4**, **17** & **20** together by using Crosshead Screw m6.3 x 40mm (**A17**). Use Allen Key (**N1**) to tighten the Crosshead Screw m6.3 x 40mm (**A17**).

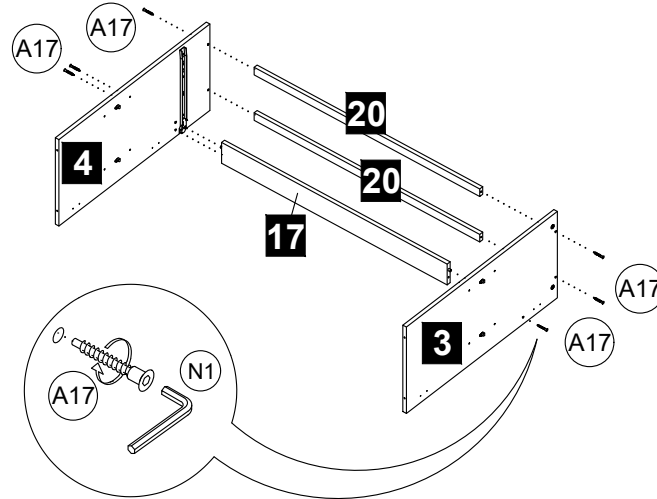

**STEP 14** Assemble the panel no. **14** by using Crosshead Screw m6.3 x 40mm (**A17**). Use Allen Key (**N1**) to tighten the Crosshead Screw m6.3 x 40mm (**A17**).

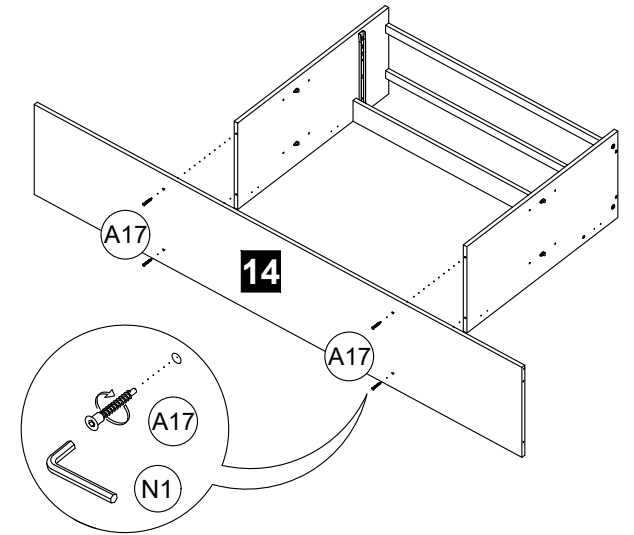

**STEP 15** Assemble the panel no. **1** & **2** by using Crosshead Screw m6.3 x 40mm (**A17**). Use Allen Key (**N1**) to tighten the Crosshead Screw m6.3 x 40mm (**A17**) & button the screw head by using Crosshead Cover (**Y**).

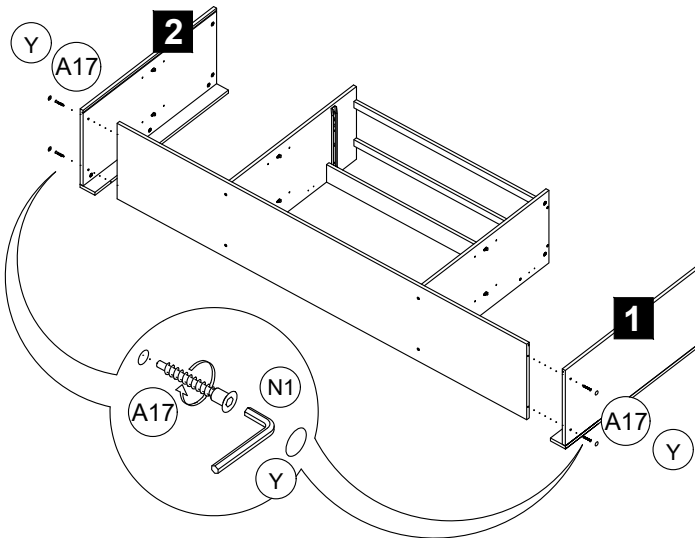

**STEP 16** Slide the panel no. **21** along the groove until end.

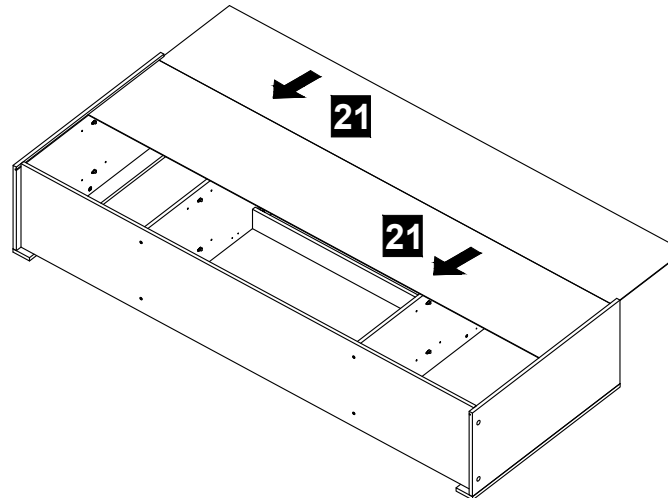

**STEP 17** Assemble the panel no. **13** by using Mini Fix 15mm (**F2**). Assemble the PVC Round Leg 25mm (**L10**) by using the Screw (**A7**) at bottom of panel no. **14**.

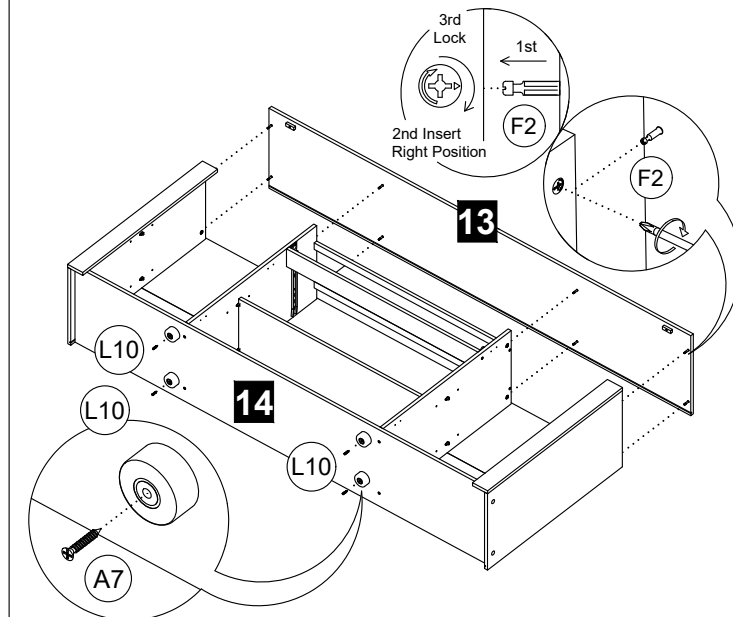

**STEP 18** Attach the back panel no. **21** by using Nail (**N3**) & use Single Plastic Cap (**R2**) to secure the back panel no. **21**.

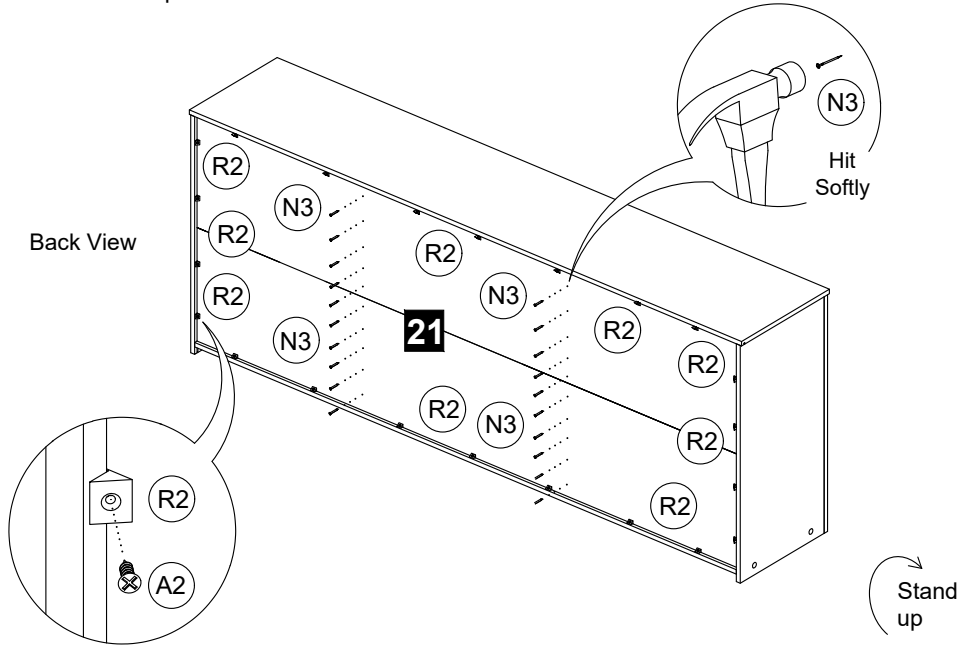

**STEP 19** Insert the panel no. **16** to the unit. Adjust the door & adjust the Hinges 2/8 (**E7**) screw to parallel between a door gaps. Assemble the Handle (**H6**) by using Screw m4 x 30mm (**A7**) at both door panel.

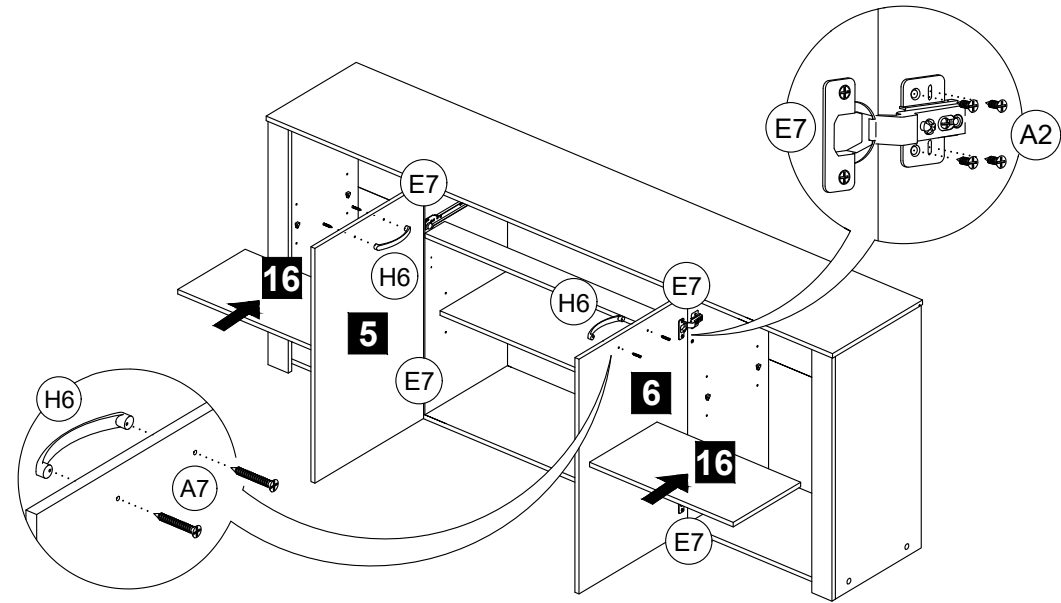

**STEP 20** Insert the panel no. **15** to the unit. Adjust the door & adjust the Hinges 2/8 (**E7**) screw to parallel between a door gaps. Assemble the Handle (**H6**) by using Screw m4 x 30mm (**A7**) at both door panel.

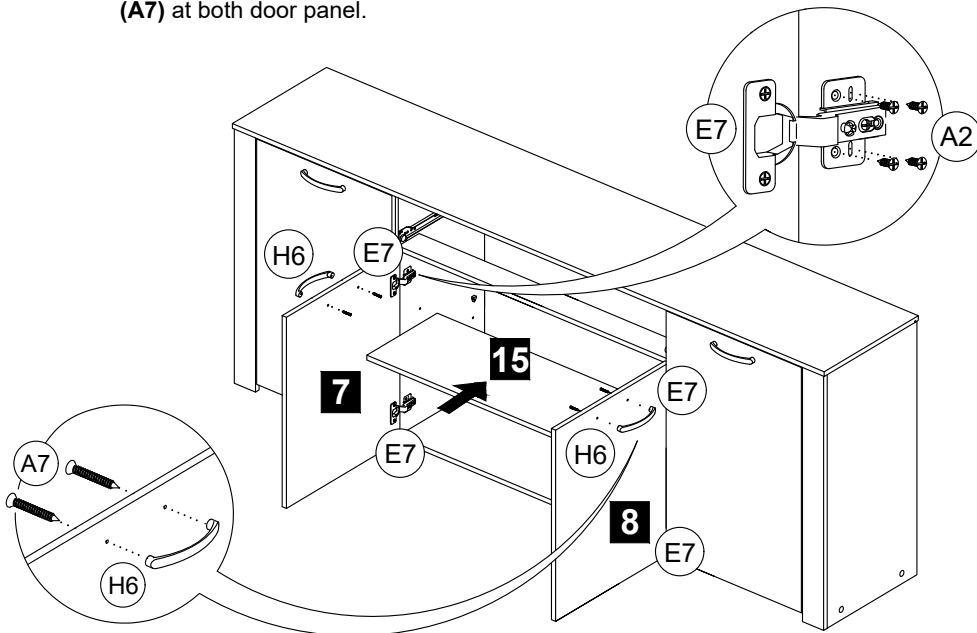

**STEP 21** Insert the drawer to the unit.

