







HARDWARE ITEM			QTY
A15		Screw JCBCW m6 x 38mm	8
D6		Wood Dowel 8 x 25mm	4
F2		Mini Fix 15mm	10 Sets
L1		Leg Pin	4
N1		Allen Key	1
Y		Mini Fix Plastic Cap	8



PRE - ASSEMBLY

STEP 1 Insert the Mini Fix Bolt 15mm (F2) at panel no. 1 & Mini Fix Cam (F2) at panel no. 2, 3 & 5. Insert the Wood Dowel 8 x 25mm (D6) at panel no. 5.

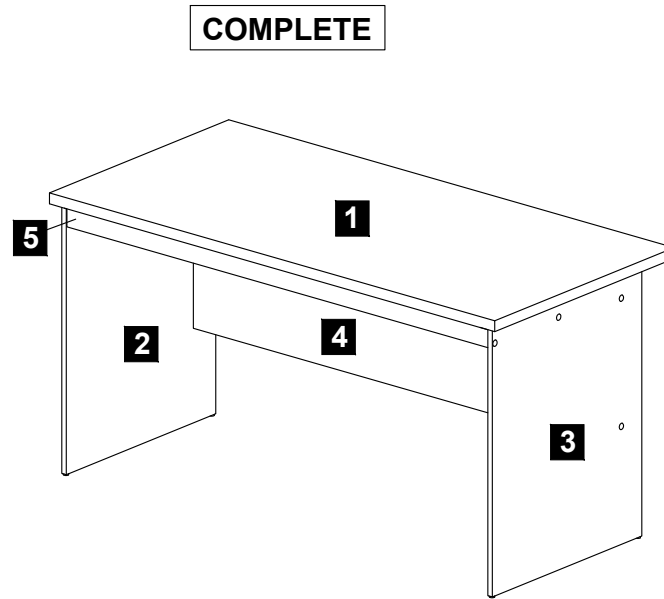
CAUTION

MATERIAL USE LAMINATED PARTICLE BOARD, TO CLEAN USE SOFT, DRY CLOTH. DO NOT USE DETERGENT OR CHEMICAL AVOID CONTACT WITH WATER AND DIRECT SUNLIGHT. TO BE ASSEMBLED ON A SOFT, DRY, CLEAN SMOOTH SURFACE.

USE OF POWER TOOLS TO ASSEMBLE THIS PRODUCT WILL INVALIDATE ANY CLAIM AND MAY DAMAGE THIS PRODUCT MAKING IT UNSAFE.



STEP 2 Assemble panel no. 2, 3, 4 & 5 together by using Screw JCBCW m6 x 38mm (A15). Use Allen Key (N1) to tighten the Screw JCBCW m6 x 38mm (A15) & button the screw head with Mini Fix Plastic Cap (Y). Nail the Leg Pin (L1) at the bottom of panel no. 2 & 3.

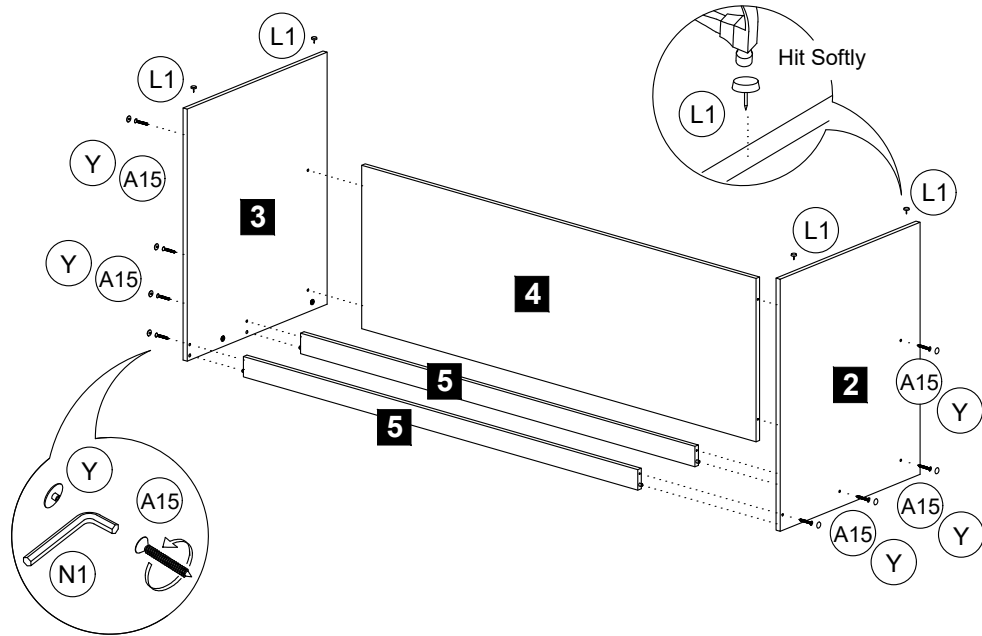

STEP 3 Assemble the panel no. 1 to the unit by using Mini Fix 15mm (F2).

