

ASSEMBLY INSTRUCTION

MODEL :

/ DOUBLE BED (1600 X 2000)

123-000177

Before you begin, please follow assembly instruction carefully. Then follow them step by step.

STEP 1

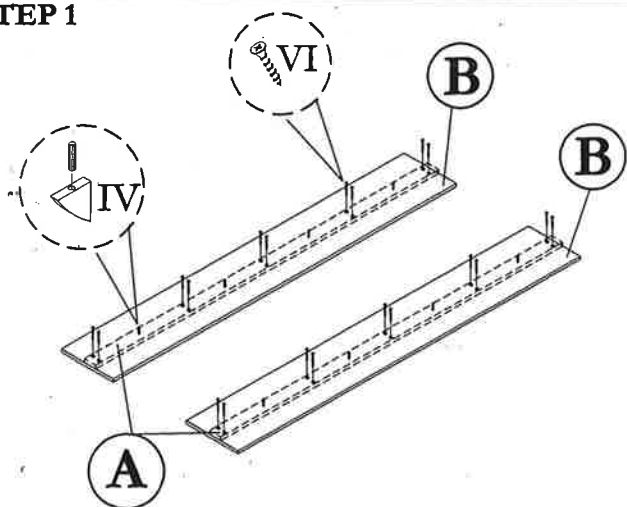

STEP 2

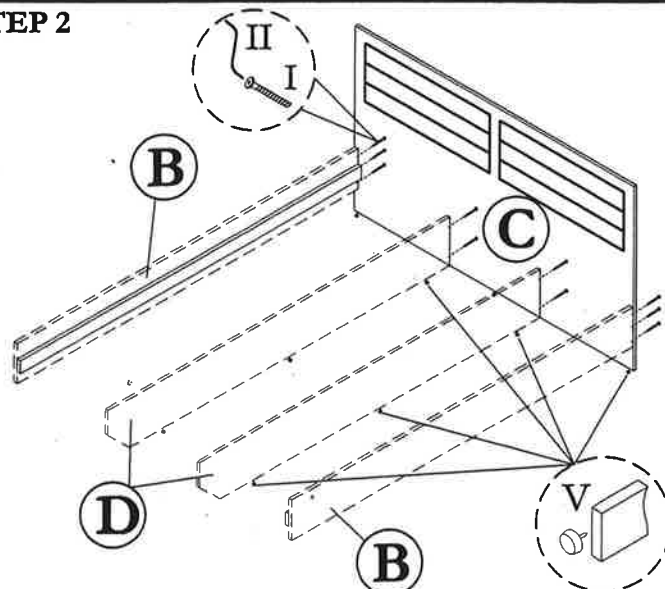

STEP 3

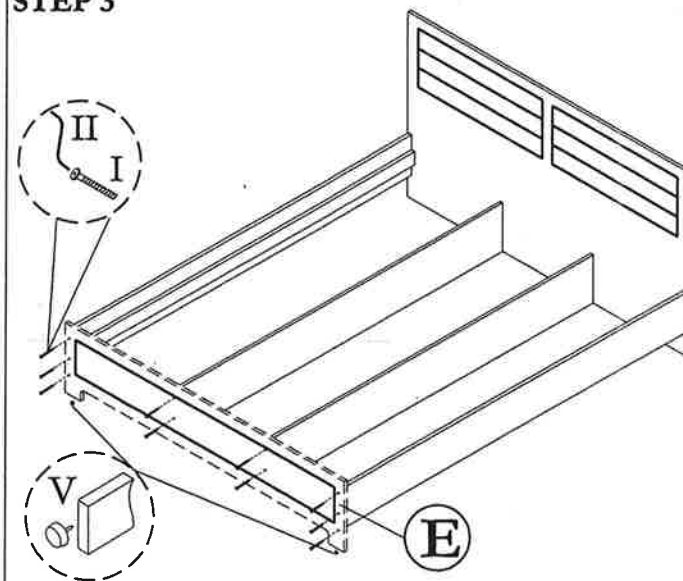

STEP 4

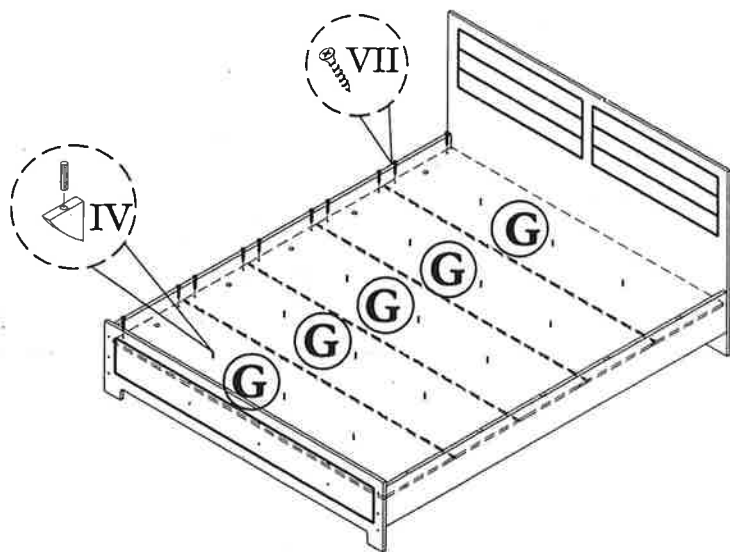

STEP 5

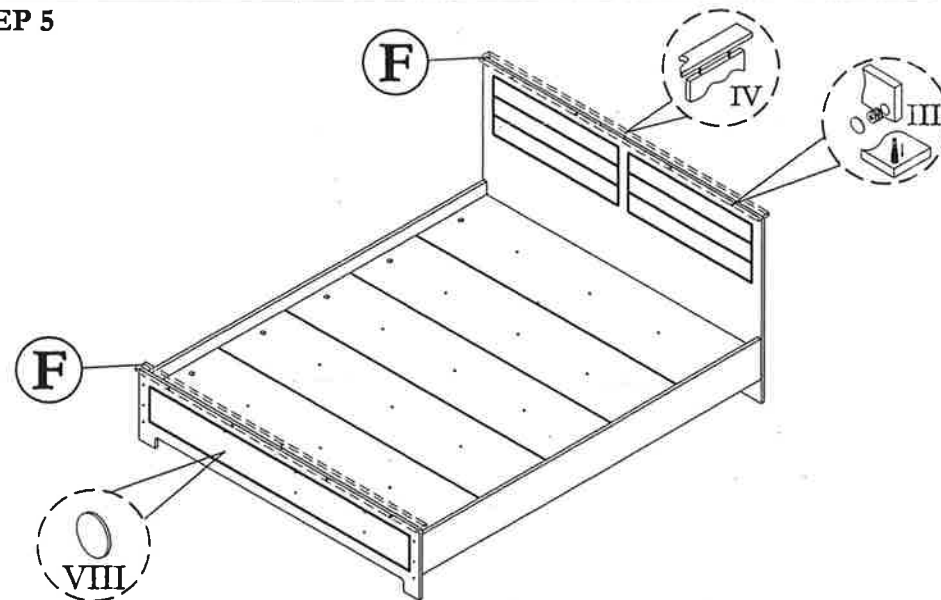

HARDWARE LIST			
NO	DESCRIPTION		QTY
I	JCBCW SCREW M6.3 x 65		20pcs
II	M4 ALLEN KEY		1pc

III	Q-FIT		6sets
IV	M8 x 30 DOWEL		22pcs
V	PVC NAIL WITH PIN		11pcs
VI	M3.5 x 30 CHIPBOARD SCREW		20pcs

VII	M4 x 25 CHIPBOARD SCREW		20pcs
VIII	STICKER		20pcs

CAUTION:

To clean use soft, dry cloth. Do not use detergent or chemicals
Avoid contact with water and direct sunlight.
To be assembled on a soft, dry, clean and smooth surface.

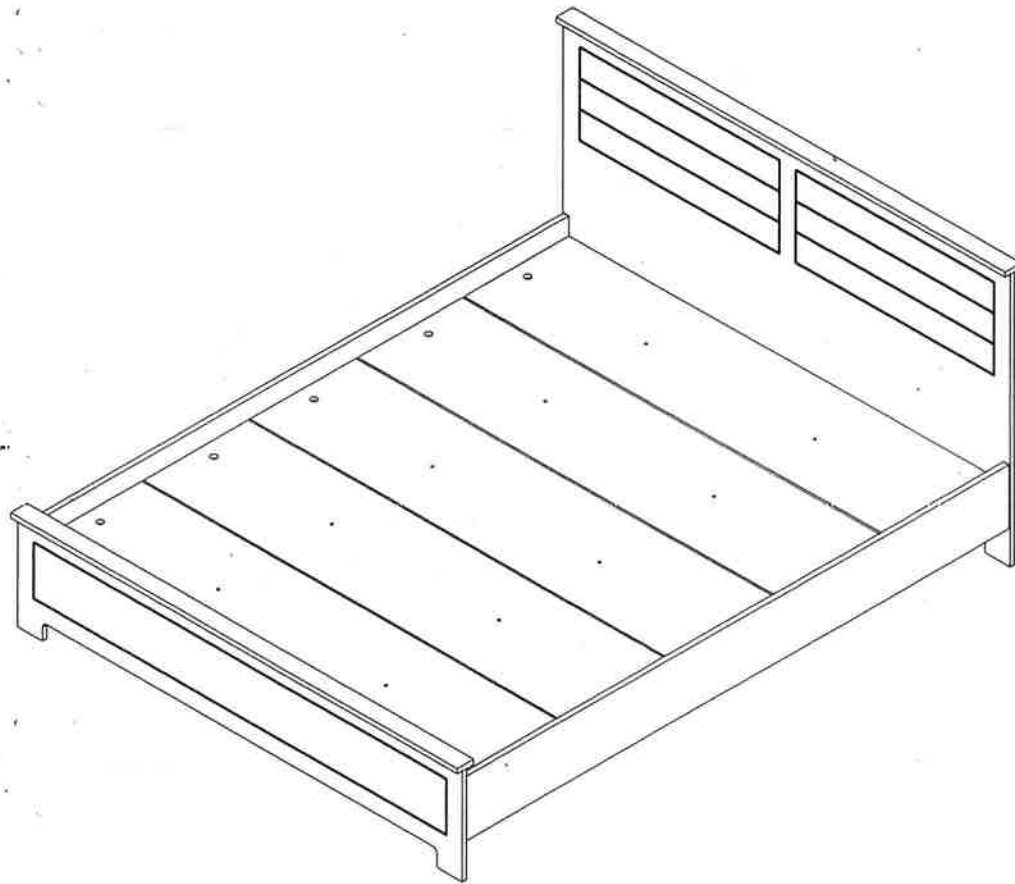

COMPLETE SET

ORDERING REPAIR PARTS

In order to obtain smooth and rapid service when ordering repair parts,
please give full attention to the following of PART NUMBER.

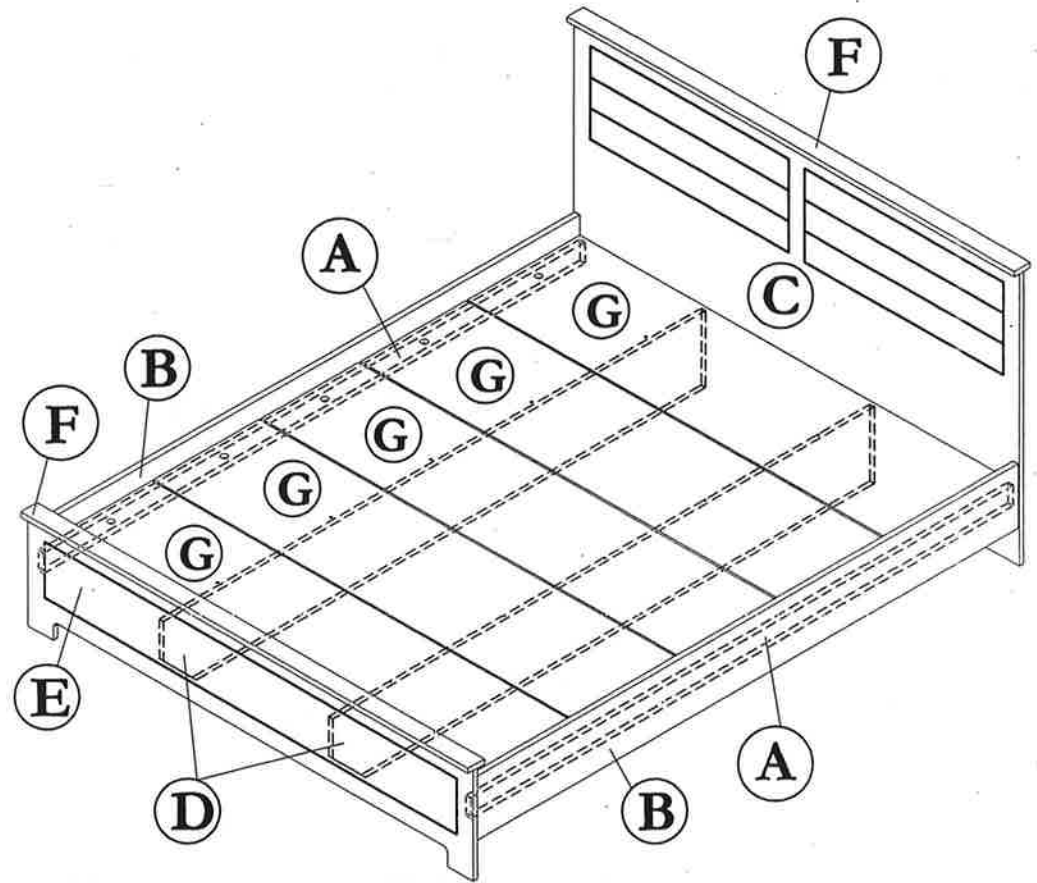

NO	DESCRIPTION	QTY
A	SIDE SUPPORT	02
B	LEFT/RIGHT SIDE	02
C	BACK VERTICAL	01
D	CENTRE VERTICAL	02

NO	DESCRIPTION	QTY
E	FRONT VERTICAL	01
F	WRAPPING	02
G	DECORATIVE BOARD	05