

# ASSEMBLY INSTRUCTION

MODEL : / CHEST OF DRAWER

## 123-000157

Before you begin, please follow assembly instruction carefully. Then follow them step by step.

### STEP 1

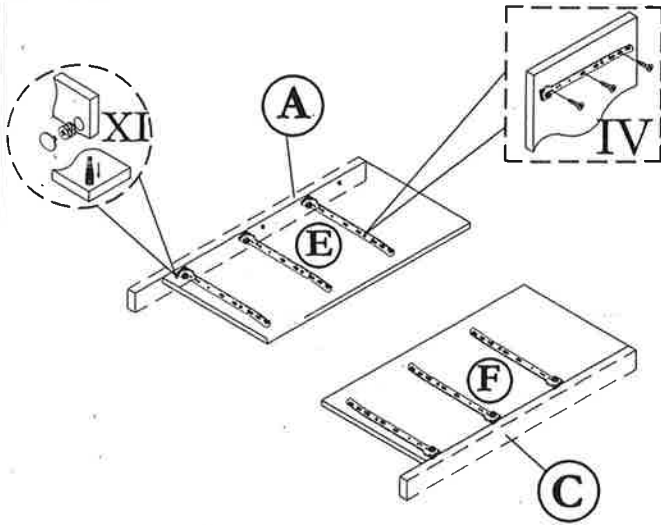

### STEP 2

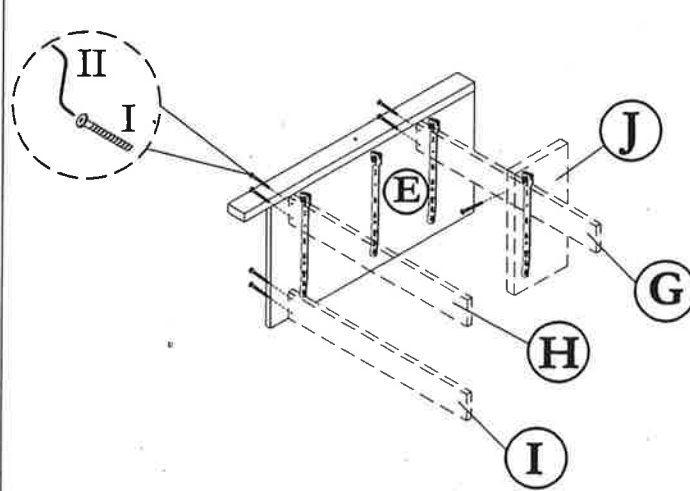

### STEP 3

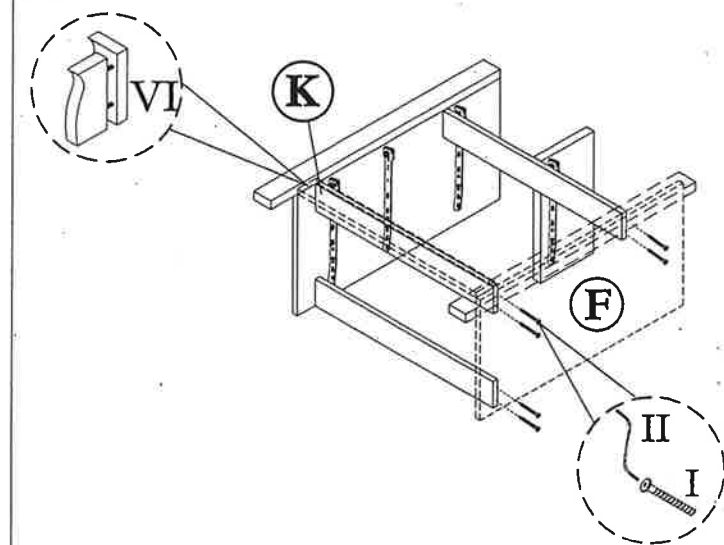

### STEP 4

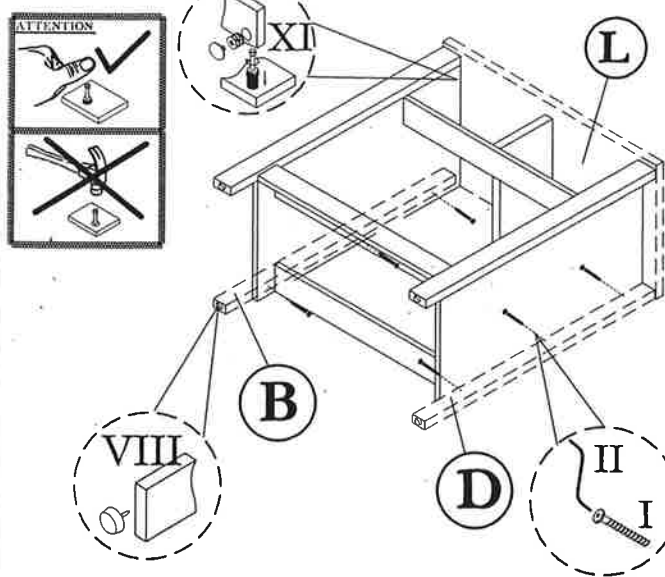

### STEP 5

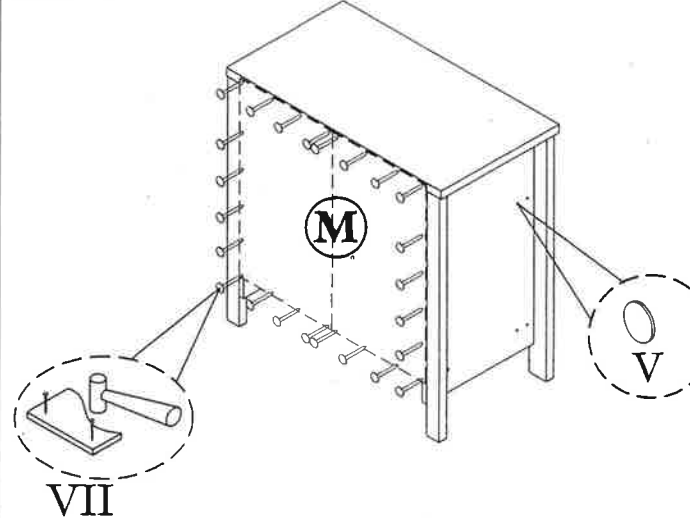

### STEP 6

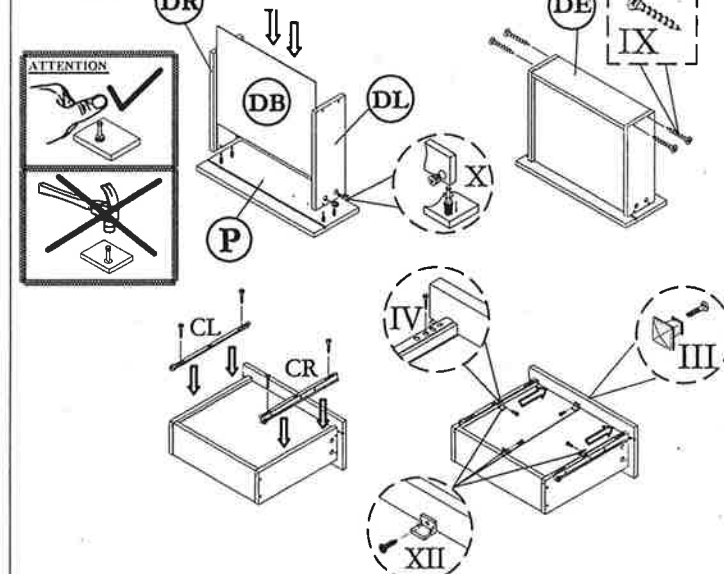

HARDWARE LIST			
NO	DESCRIPTION		QTY
I	JCBCW SCREW M6.3 x 50		19pcs
II	M4 ALLEN KEY		1pc
III	HANDLE & SCREW M4 x 22		6sets

IV	12" DRAWER SLIDER & SCREW M3.5 x 12		4sets
V	STICKER		10pcs
VI	M8 x 30 WOOD DOWEL		4pcs
VII	NAIL		40pcs
VIII	PVC NAIL WITH PIN		4pcs

IX	M8 x 32 CHIPBOARD SCREW		16pcs
X	Q-FIT		22sets
XI	Q-FIT (small)		6sets
XII	DRAWER SUPPORT & SCREW M3.5 x 12		8sets

**CAUTION:**

To clean use soft, dry cloth. Do not use detergent or chemicals  
 Avoid contact with water and direct sunlight.  
 To be assembled on a soft, dry, clean and smooth surface.

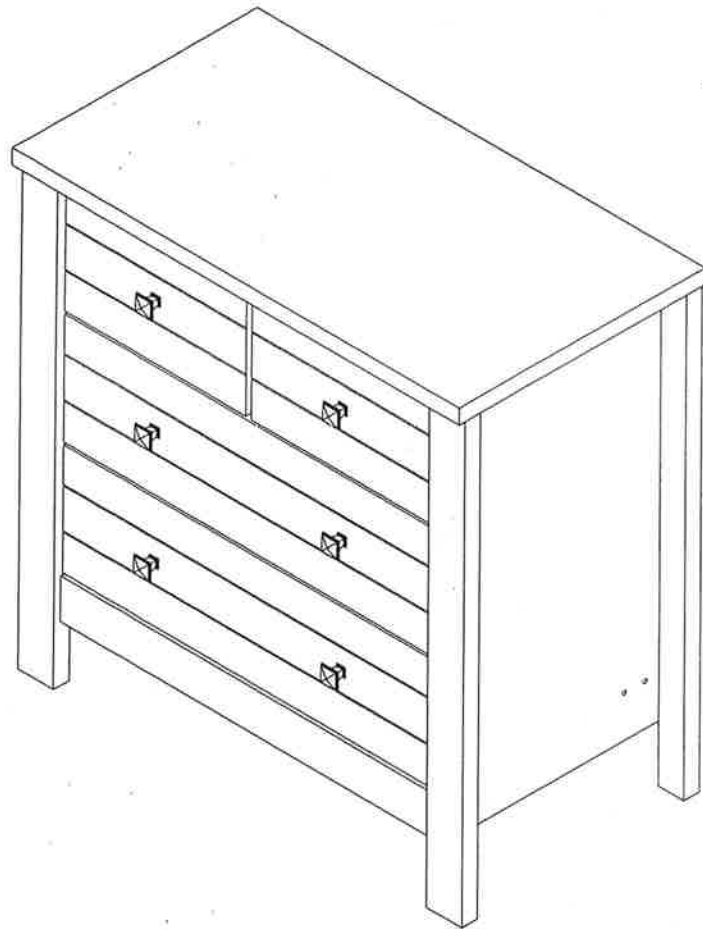

# COMPLETE SET

**ORDERING REPAIR PARTS**

In order to obtain smooth and rapid service when ordering repair parts,  
 please give full attention to the following of PART NUMBER.

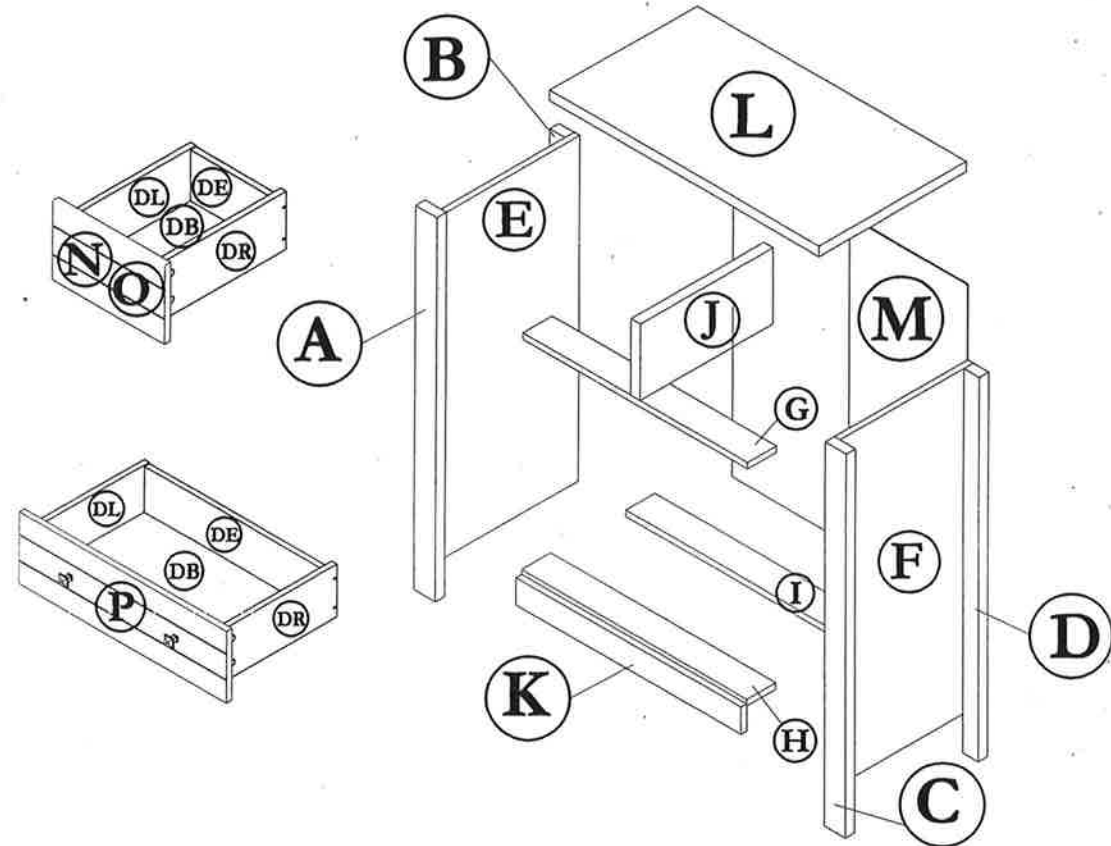

NO	DESCRIPTION	QTY
A	LEFT SIDE WRAPPING (Front)	01
B	LEFT SIDE WRAPPING (Back)	01
C	RIGHT SIDE WRAPPING (Front)	01
D	RIGHT SIDE WRAPPING (Back)	01
E	LEFT SIDE	01
F	RIGHT SIDE	01
G	CENTRE SHELF	01
H	CENTRE SHELF	01

NO	DESCRIPTION	QTY
I	CENTRE SHELF (Back)	01
J	CENTRE VERTICAL	01
K	LEG	01
L	TOP	01
M	BACK	02
N	DRAWER FACE (Left)	01
O	DRAWER FACE (Right)	01
P	DRAWER FACE	02

NO	DESCRIPTION	QTY
DL	DRAWER SIDE (Left)	04
DR	DRAWER SIDE (Right)	04
DB	DRAWER BASE	02
DE	DRAWER END	02
DB	DRAWER BASE	02
DE	DRAWER END	02