

ASSEMBLY INSTRUCTION
MODEL : 1218/ BOOKCASE



123-000152

Before you begin, please follow assembly instruction carefully.
 Then follow them step by step.

STEP 1

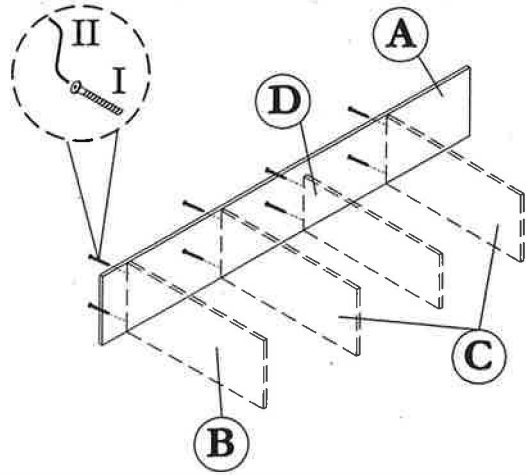

STEP 2

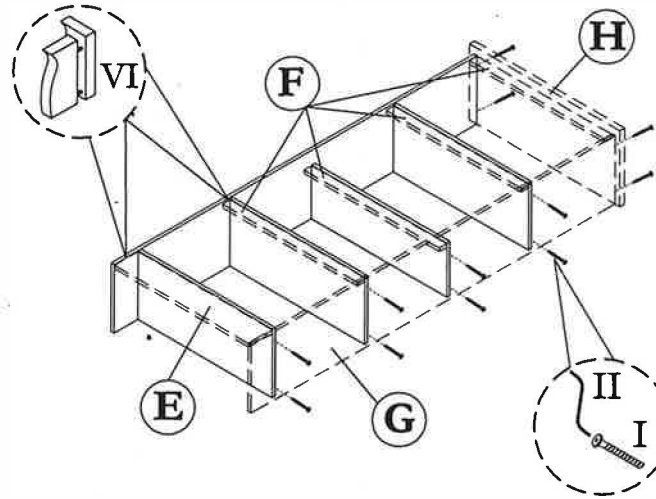

STEP 3

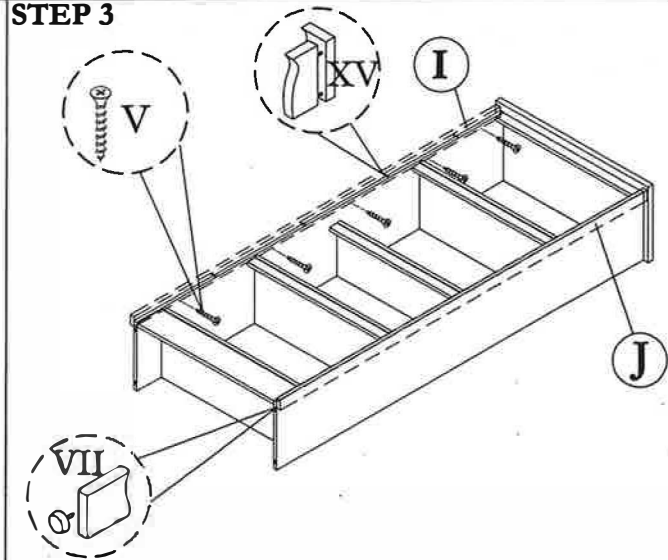

STEP 4

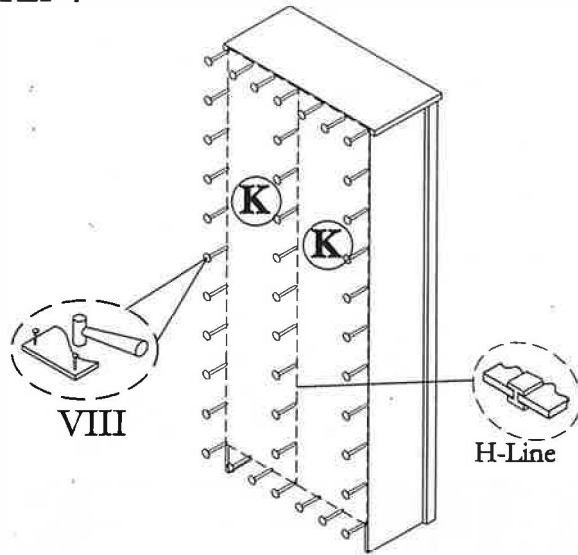

STEP 5

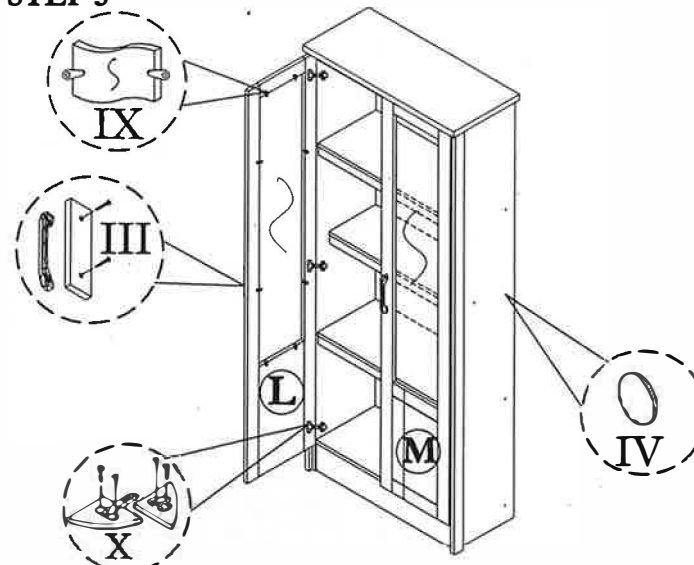

STEP 6

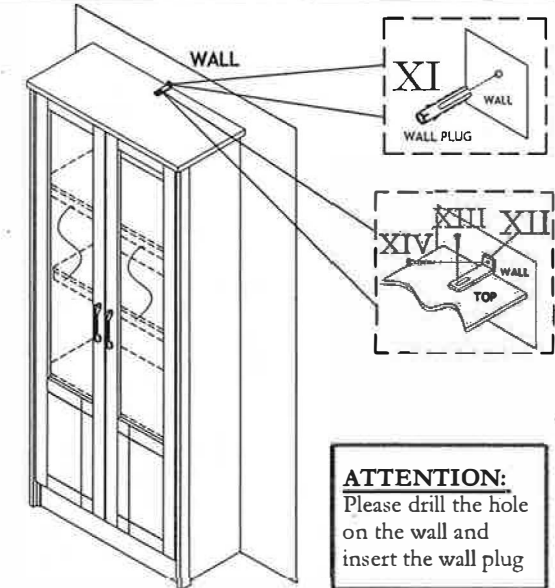

ATTENTION:
 Please drill the hole on the wall and insert the wall plug

HARDWARE LIST

NO	DESCRIPTION	QTY
I	JCBCW SCREW M6.3 x 50	20pcs
II	M4 ALLEN KEY	1pc
III	HANDLE & SCREW M4 x 22	2sets
IV	STICKER	16pcs

V	M3.5 x 30 CHIPBOARD SCREW	10pcs
VI	M8 x 30 WOOD DOWEL	12pcs
VII	PVC NAIL WITH PIN	4pcs
VIII	NAIL	50pcs
IX	PE CLIP & SCREW M3.5 X 16	16sets
X	HINGE (B) & SCREW M3.5 x 16	6sets

XI	WALL PLUG	1pc
XII	L-BRACKET	1pc
XIII	M4 x 16 CHIPBOARD SCREW	1pc
XIV	M4 x 38 CHIPBOARD SCREW	1pc
XV	M8 x 20 WOOD DOWEL	8pcs

CAUTION:

To clean use soft, dry cloth. Do not use detergent or chemicals
 Avoid contact with water and direct sunlight.
 To be assembled on a soft, dry, clean and smooth surface:

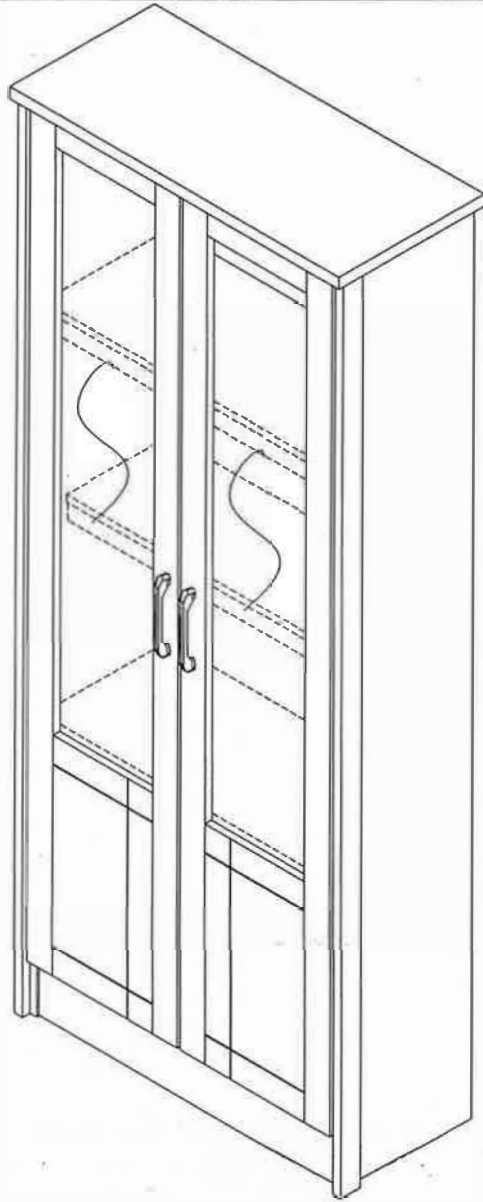

COMPLETE SET

ORDERING REPAIR PARTS

In order to obtain smooth and rapid service when ordering repair parts,
 please give full attention to the following of PART NUMBER.

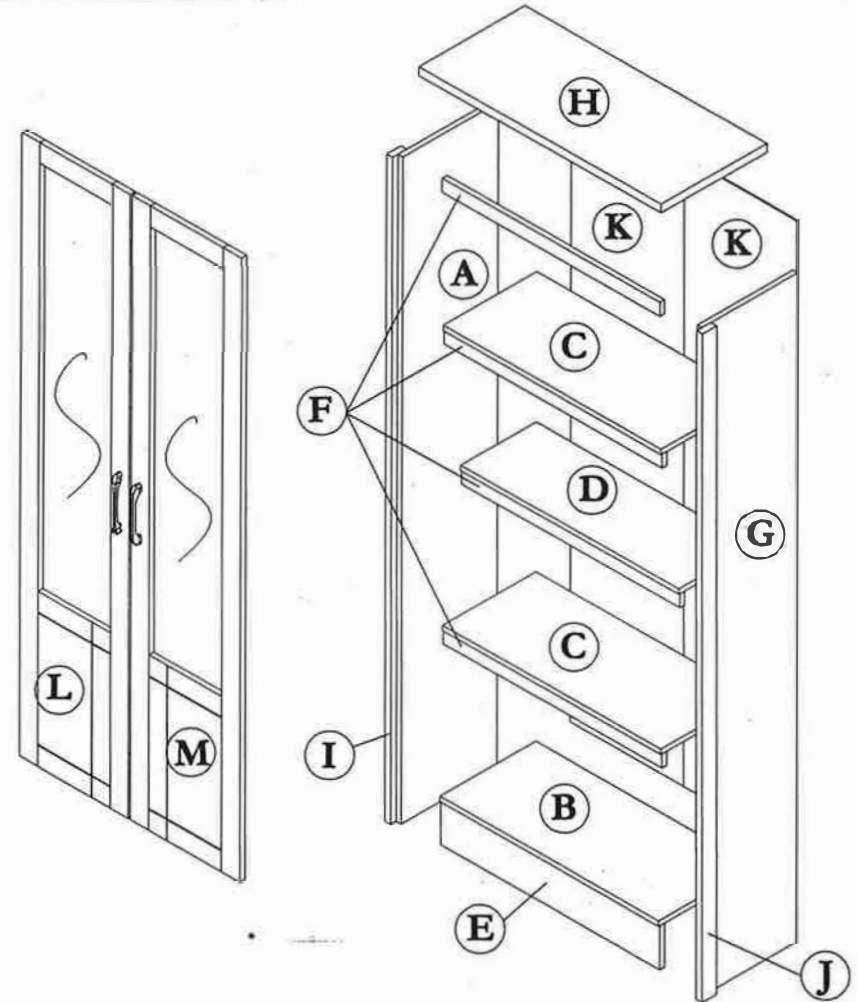

NO	DESCRIPTION	QTY
A	LEFT SIDE	01
B	LOWER SHELF	01
C	CENTRE SHELF	02
D	CENTRE SHELF	01
E	LEG	01
F	CENTRE SHELF SUPPORT	04
G	RIGHT SIDE	01

NO	DESCRIPTION	QTY
H	TOP	01
I	WRAPPING (Left)	01
J	WRAPPING (Right)	01
K	BACK	02
L	LEFT SIDE DOOR	01
M	RIGHT SIDE DOOR	01