

# ASSEMBLY INSTRUCTION

MODEL : / DRESSING TABLE

## 123-000102

Before you begin, please follow assembly instruction carefully. Then follow them step by step.

STEP 1

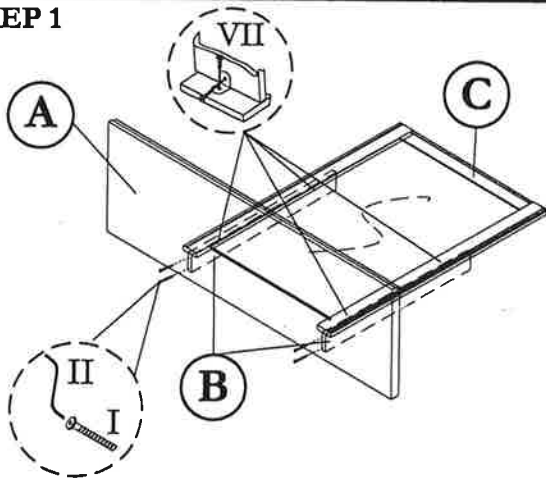

STEP 2

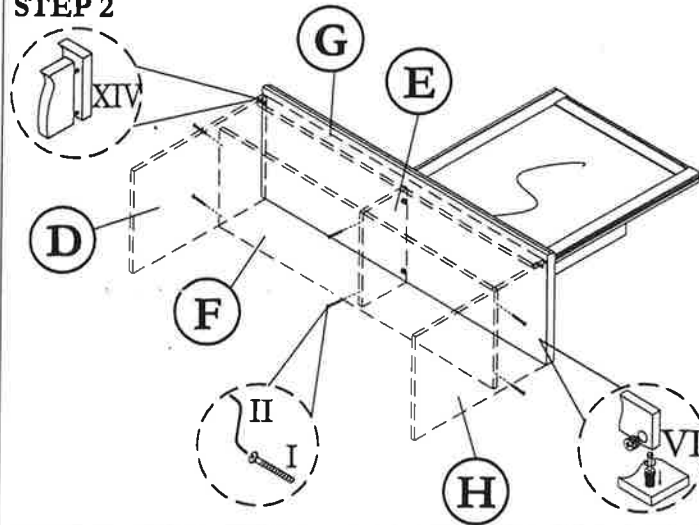

STEP 3

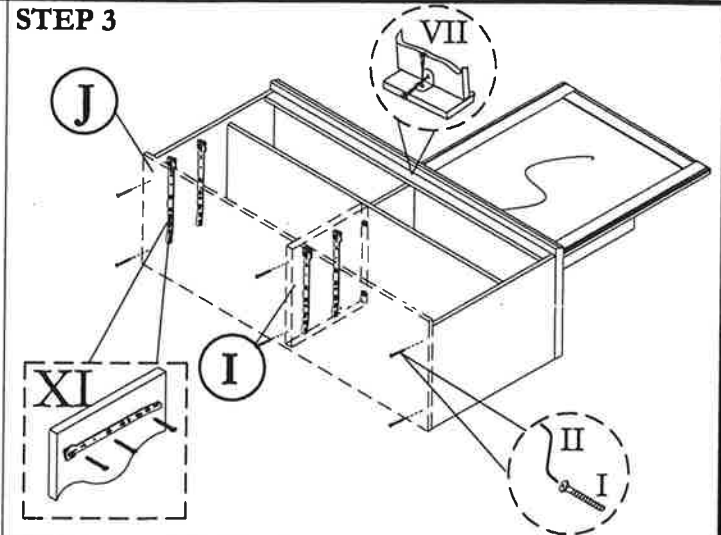

STEP 4

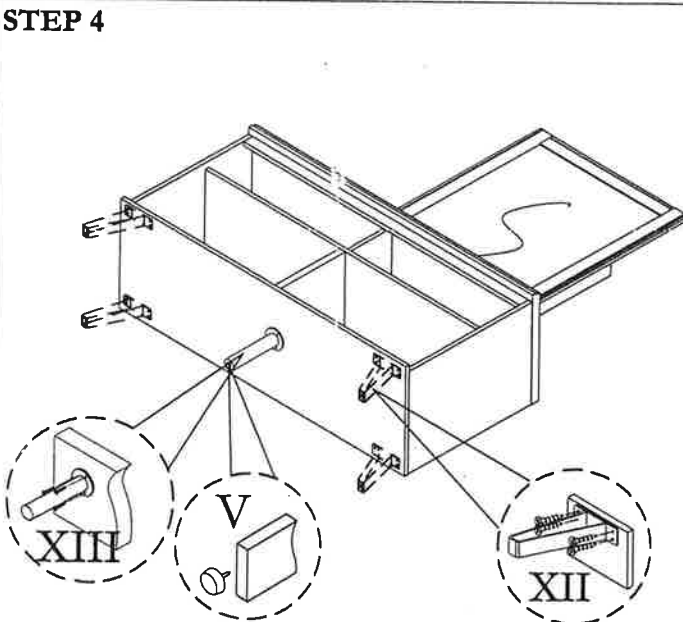

STEP 5

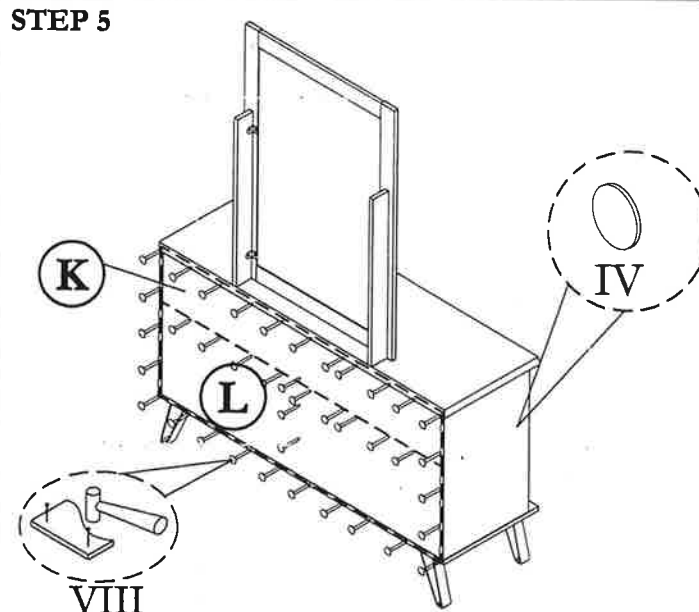

STEP 6

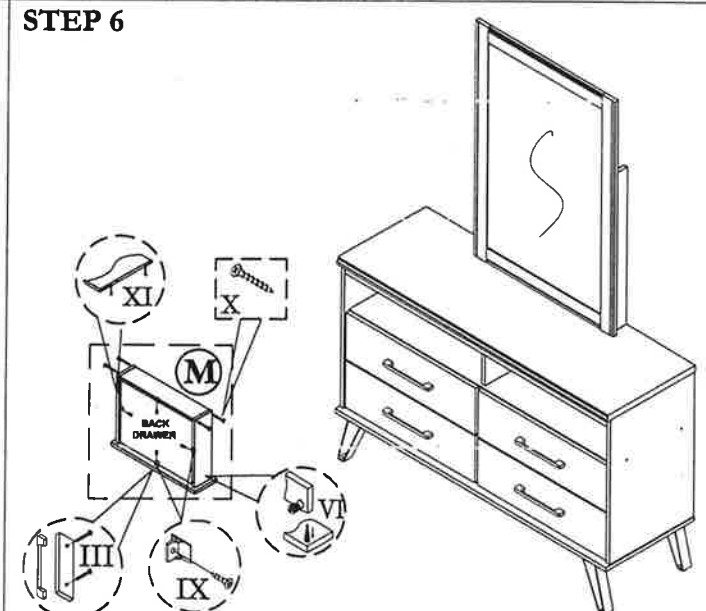

### HARDWARE LIST

NO	DESCRIPTION	QTY
I	JCBW SCREW M6.3 x 50	16pcs
II	M4 ALLEN KEY	1pc
III	HANDLE & SCREW M4 x 22	4sets
IV	STICKER	4pcs

V	PVC NAIL WITH PIN	1pc
VI	Q-FIT	24sets
VII	L BRACKET & SCREW M3.5 x 12	5sets
VIII	NAIL	50pcs
IX	DRAWER SUPPORT & SCREW M3.5 x 12	16sets
X	M8 x 32 CHIPBOARD SCREW	16pcs

XI	12" DRAWER SLIDER & SCREW M3.5 x 12	4sets
XII	180mm METAL LEG & SCREW M4 x 18	4sets
XIII	180mm PLASTIC LEG & SCREW M3.5 x 16	1sets
XIV	M8 x 30 WOOD DOWEL	2pcs

**CAUTION:**

To clean use soft, dry cloth. Do not use detergent or chemicals  
Avoid contact with water and direct sunlight.  
To be assembled on a soft, dry, clean and smooth surface.

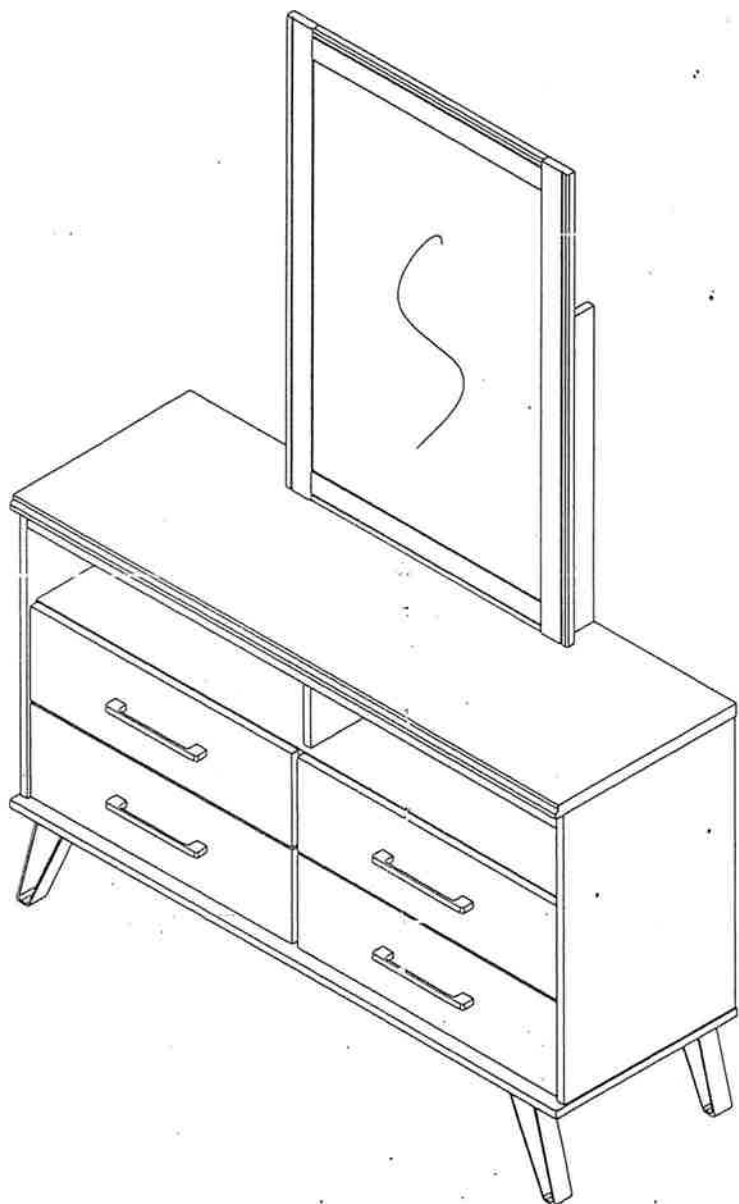

**COMPLETE SET**

**ORDERING REPAIR PARTS**

In order to obtain smooth and rapid service when ordering repair parts,  
please give full attention to the following of PART NUMBER.

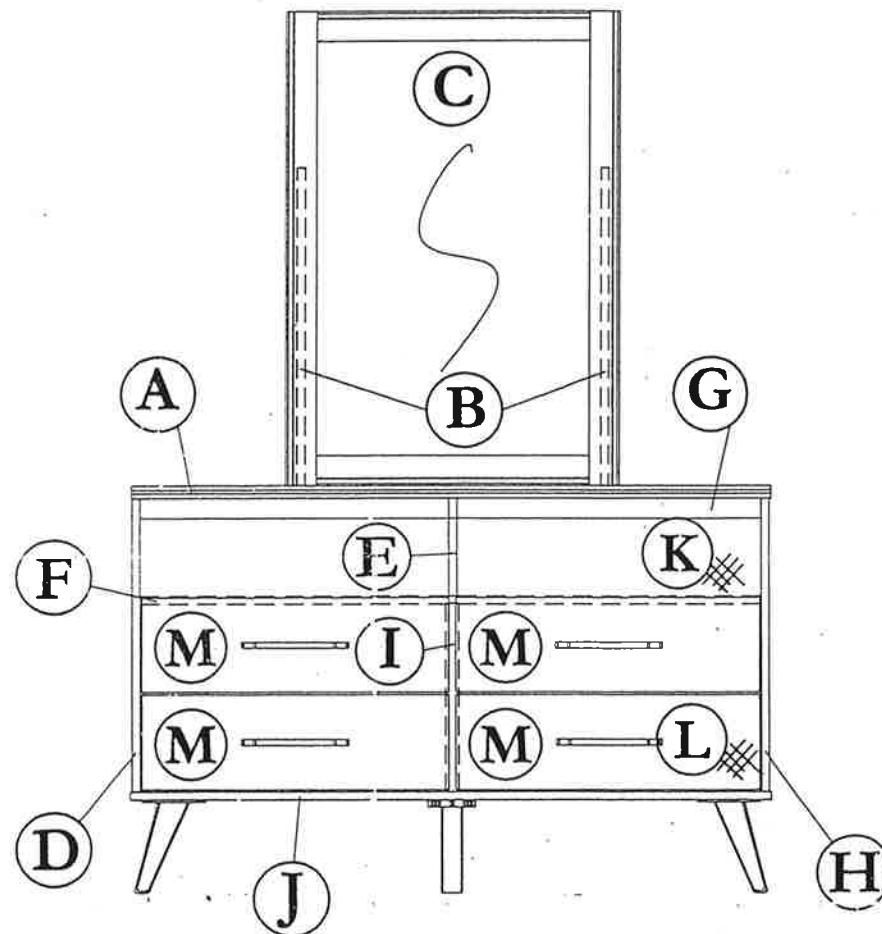

NO	DESCRIPTION	QTY
A	TOP	01
B	VERTICAL GLASS SUPPORT	02
C	VERTICAL GLASS	01
D	LEFT SIDE	01
E	CENTRE VERTICAL	01
F	CENTRE SHELF	01
G	TOP SUPPORT	01

NO	DESCRIPTION	QTY
H	RIGHT SIDE	01
I	CENTRE VERTICAL	01
J	LOWER SHELF	01
K	BACK (Top)	01
L	BACK (Bottom)	01
M	DRAWER FACE	04