

# Assembly Instruction

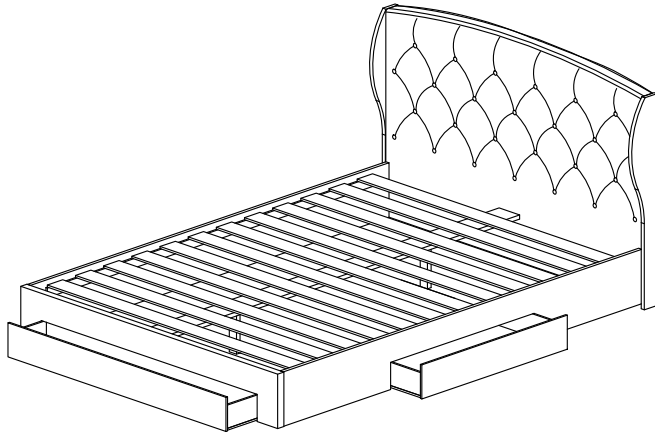

Hardware List			
No.	SHAPE	DESCRIPTION	Qty.
A		M4x25mm Screw	36Pcs
B		M4x45mm Screw	20Pcs
C		M3.5x16mm Screw	32Pcs
D		JCBC M6x30mm	2Pcs
E		JCBC M6x35mm	8Pcs
F		JCBB M8x20mm	16Pcs
G		Dowel 8x25	16Pcs
H		Flat Washer M6 x 19	8Pcs
I		L Key M4	1Pcs
J		L Key M5	1Pcs
K		Caster	8Pcs

Part List		
No.	Part Name	Qty.
1	Head Board	1Pcs
2&3	Head Post	2Pcs
4	Foot Board	1Pcs
5	Center Slats	1Pcs
6	LVL Slats	12Pcs
7&8	Side Rail	2Pcs
9	Center Leg Support	2Pcs
10&11	Drawer Side Panel	4Pcs
12	Drawer End Panel - Big	1Pcs
13	Drawer Base Panel - Big	1Pcs
14	Drawer Front Panel - Big	1Pcs
15	Drawer Front Panel - Small	1Pcs

16	Drawer End Panel - Small	1Pcs
17	Drawer Base Panel - Small	1Pcs

## Part List

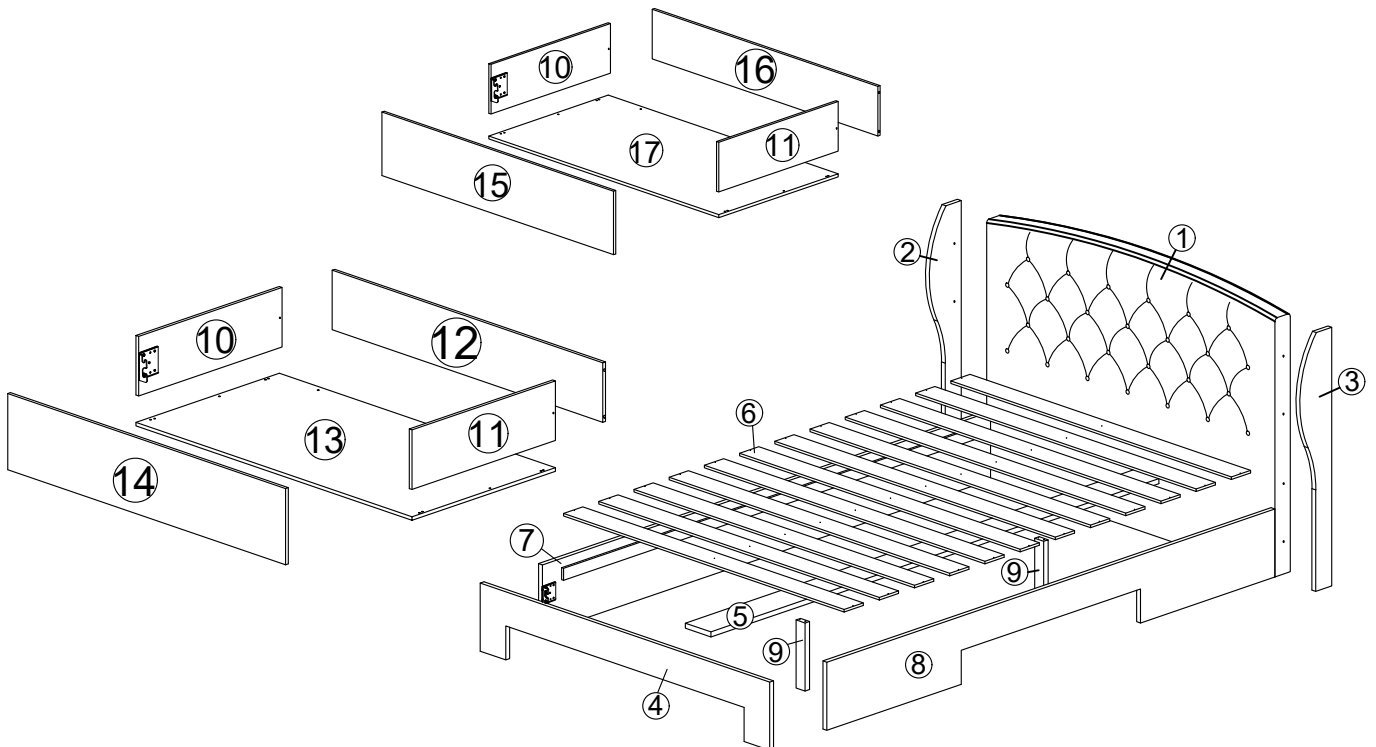

# Assembly Instruction

## Step 1

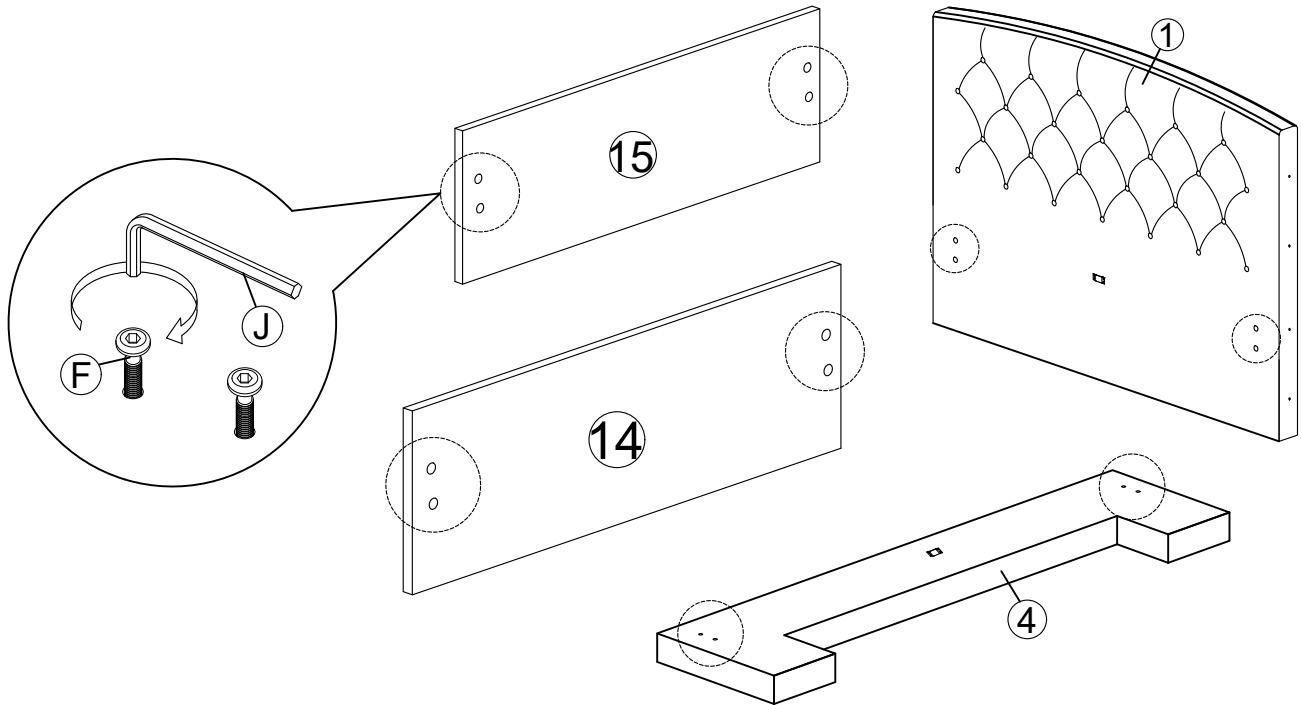

## Step 2

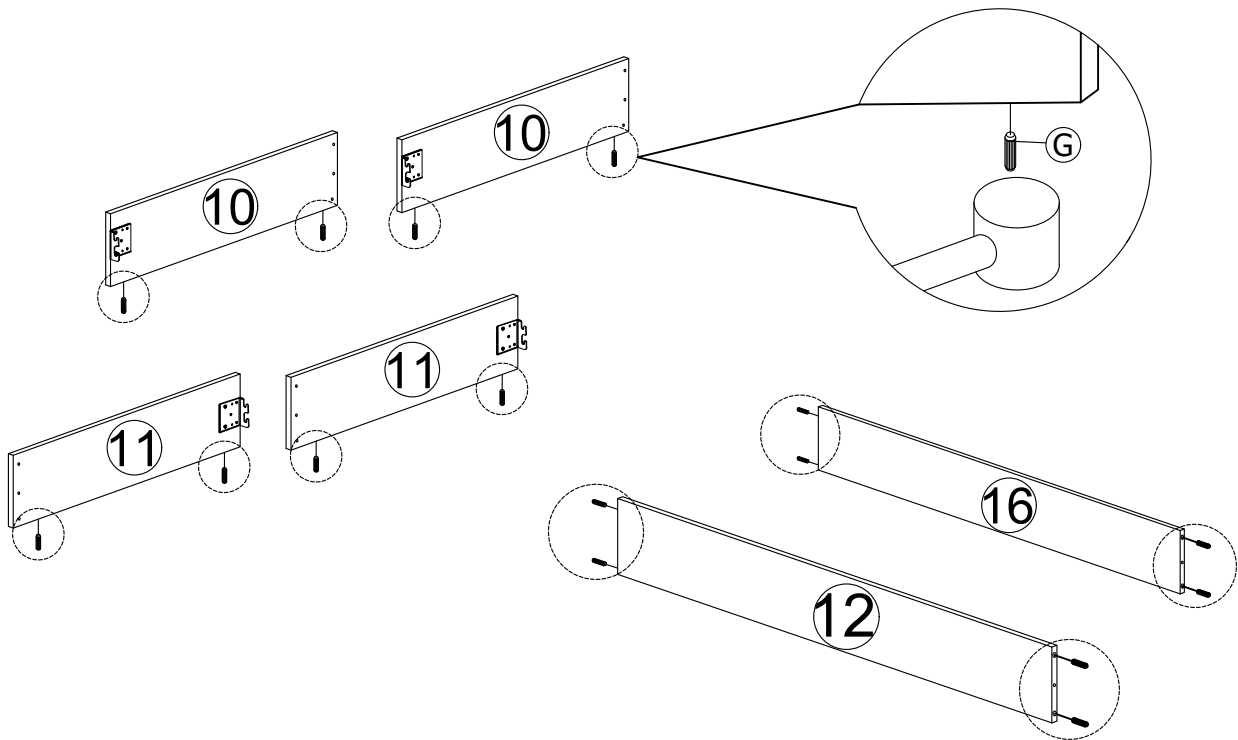

# Assembly Instruction

## Step 3

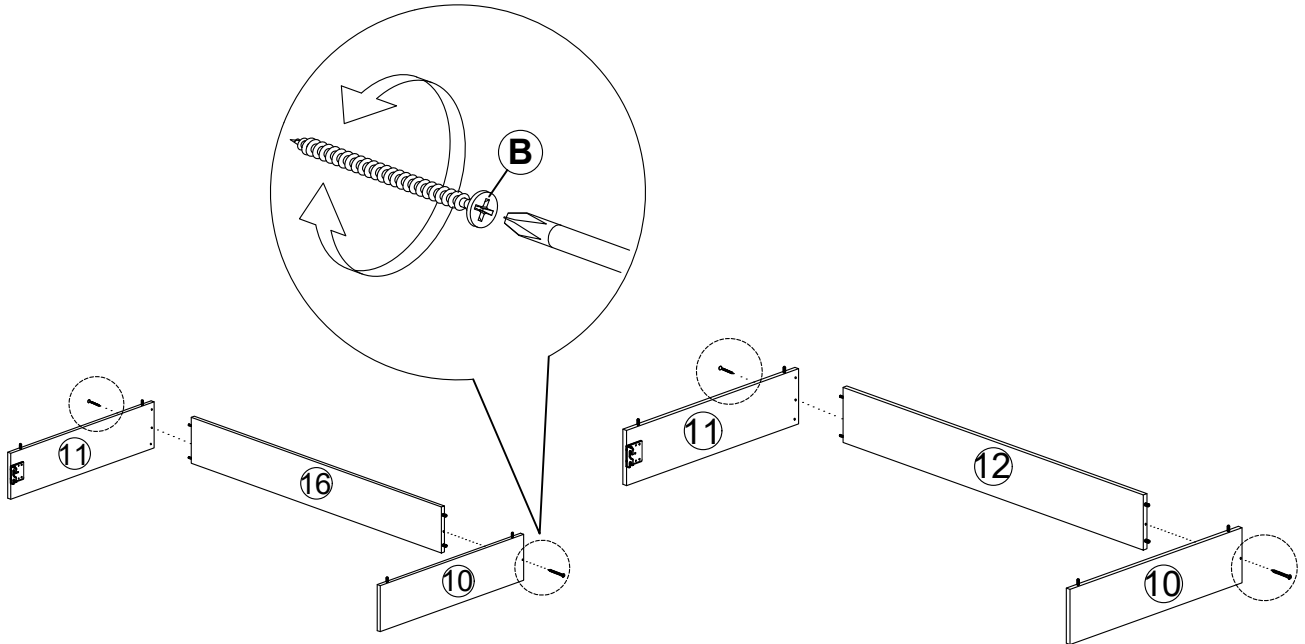

## Step 4

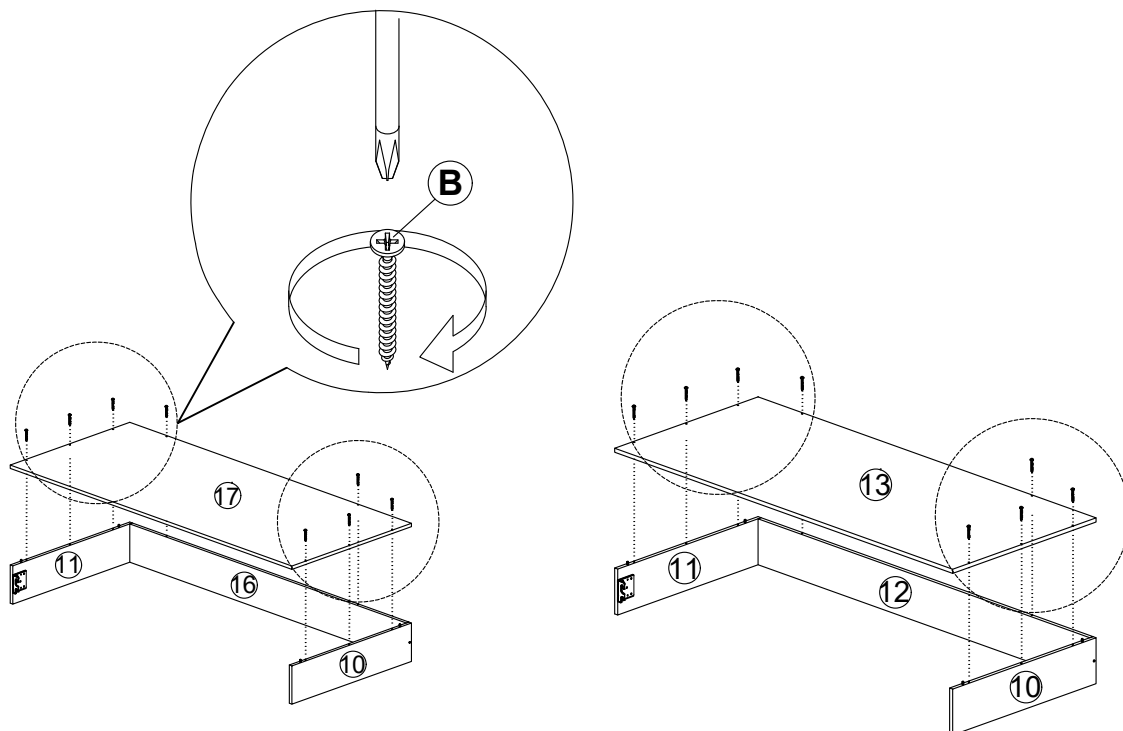

# Assembly Instruction

Step 5

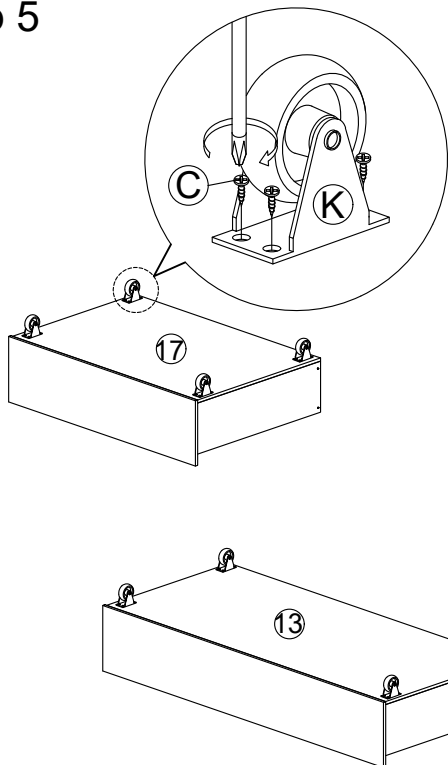

Step 6

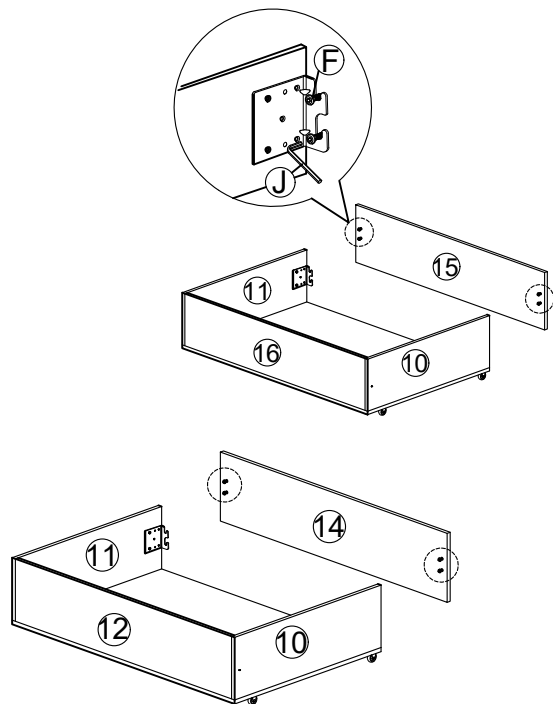

Step 7

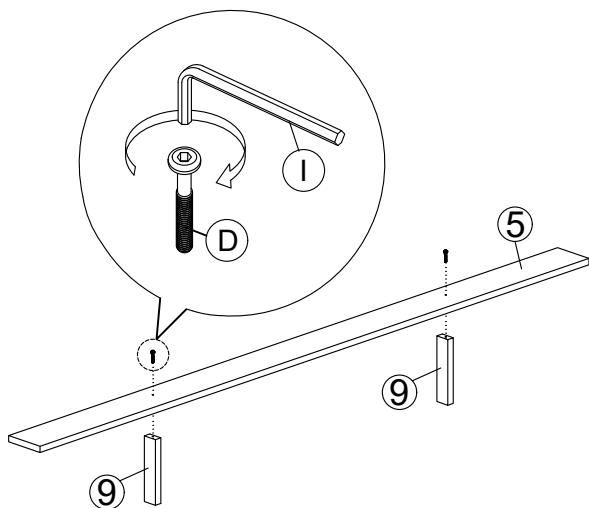

Step 8

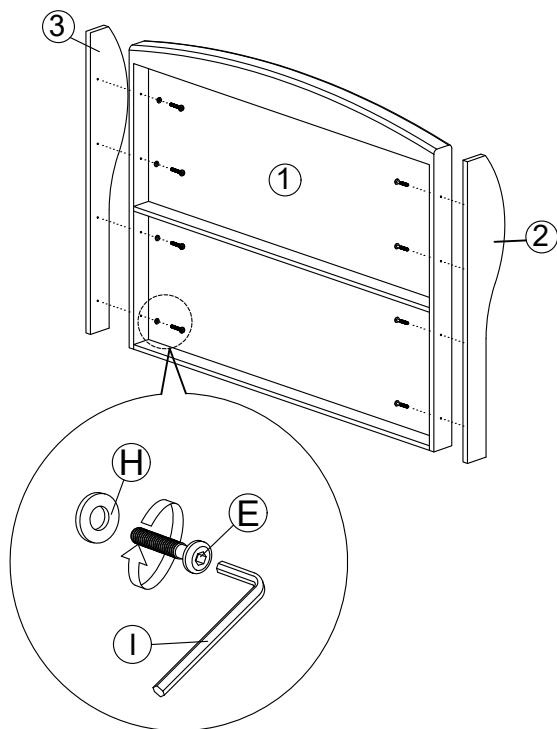

# Assembly Instruction

Step 9

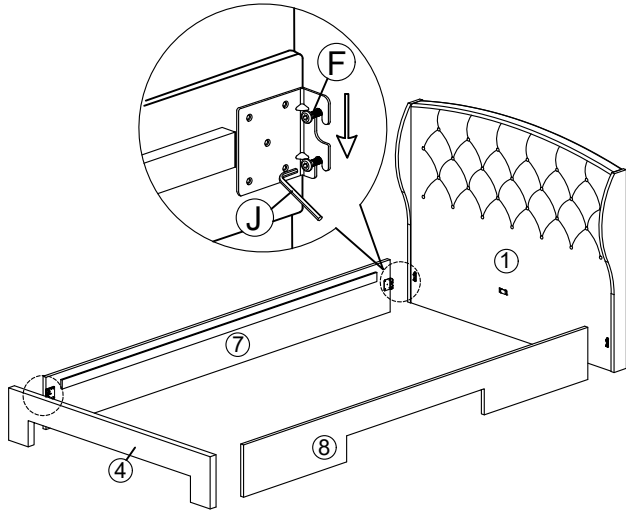

Step 10

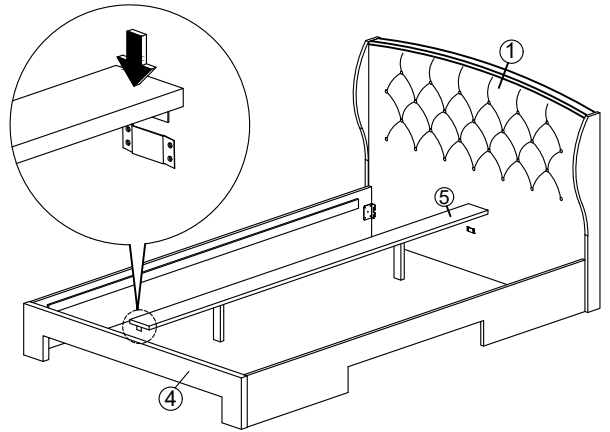

Step 11

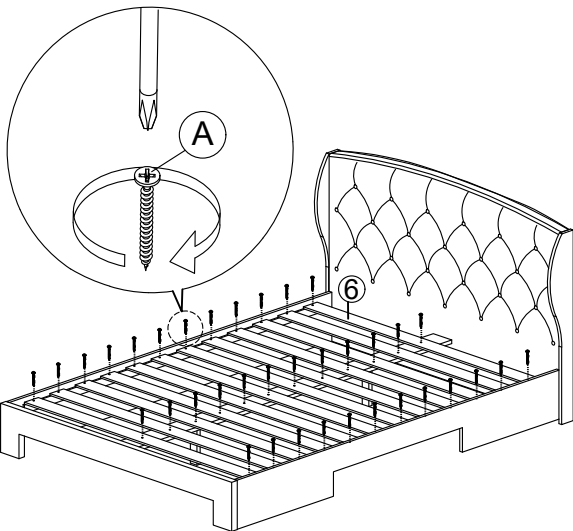

Step 12

